

TS0027UK04

# Riello 40 FS Series

## One Stage Gas Burners



<b>FS3</b>	11 ÷	35 kW
<b>FS5</b>	23 ÷	58 kW
<b>FS8</b>	46 ÷	93 kW
<b>FS10</b>	42 ÷	116 kW
<b>FS20</b>	81 ÷	220 kW

The Riello 40 FS series of one stage gas burners, is a complete range of products developed to respond to any request for light industrial application. The Riello 40 FS series is available in five different models, with an output ranging from 11 to 220 kW, divided in four different structures.

All the models use the same components designed by Riello for the Riello 40 FS series. The high quality level guarantees safe working.

The Riello 40 FS burners are fitted with a microprocessor - based flame control panel, with diagnostic functions.

In developing these burners, special attention was paid to reducing noise, to the ease of installation and adjustment, to obtaining the smallest size possible to fit into any sort of boiler available on the market.

All the models are approved by the EN 676 European Standard and conform to European Directives for EMC, Low Voltage, Machinery and Boiler Efficiency.

All the Riello 40 FS burners are tested before leaving the factory.



## Technical Data

MODEL		FS3	FS5	FS8	FS10	FS20
Burner operation mode		One stage				
Modulation ratio at max. output		--				
Servomotor	type	--				
	run time s	--				
Heat output	kW	11 - 35	23 - 58	46 - 93	42 - 116	81 - 220
	Mcal/h	9,5 - 30	20 - 50	40 - 80	36 - 100	70 - 189
Working temperature	°C min./max.	0/40				
<b>FUEL/AIR DATA</b>						
Net calorific value G20 gas	kWh/Nm <sup>3</sup>	10				
Density gas G20	kg/Nm <sup>3</sup>	0,71				
Output gas G20	Nm <sup>3</sup> /h	1,1 - 3,5	2,3 - 5,8	4,6 - 9,3	4,2 - 11,6	8,1 - 22
Net calorific value G25 gas	kWh/Nm <sup>3</sup>	8,6				
Density gas G25	kg/Nm <sup>3</sup>	0,78				
Output gas G25	Nm <sup>3</sup> /h	1,3 - 4	2,7 - 6,7	5,3 - 10,8	4,9 - 13,4	9,5 - 25,6
Net calorific value LPG gas	kWh/Nm <sup>3</sup>	25,8				
Density LPG gas	kg/Nm <sup>3</sup>	2,02				
Output LPG gas	Nm <sup>3</sup> /h	0,4 - 1,4	0,9 - 2,2	1,8 - 3,6	1,6 - 4,4	3,1 - 8,5
Fan	Type	Centrifugal with forward curve blades				
Air temperature	Max. °C	40				
<b>ELECTRICAL DATA</b>						
Electrical supply	Ph/Hz/V	1/50/230 ±10%				
Auxiliary electrical supply	Ph/Hz/V	--				
Control box	Type	MG 557/5	MG 557/3	RMG 88.620A2		
Total electrical power	kW	0,100	0,110	0,130	0,130	0,250
Auxiliary electrical power	kW	--				
Protection level	IP	X0D				
Motor electrical power	kW	0,09	0,09	0,09	0,09	0,15
Rated motor current	A	0,6	0,65	0,7	0,7	1,4
Motor start current	A	2,4	2,6	2,8	2,8	5,6
Motor protection level	IP	20				
Ignition transformer	type	Incorporated in the control box			Separated from the control box	
	V1 - V2	(-) - 8 kV			230 V - 8 kV	
	I1 - I2	(-) - 12 mA			1,8 A - 30 mA	
Operation		Intermittent (at least one stop every 24 h)				
<b>EMISSIONS</b>						
Sound pressure	dB(A)	56	60	66	67	73
Sound output	W	--				
CO Emission	mg/kWh	< 40				
NOx Emission	mg/kWh	≤ 120				
<b>APPROVAL</b>						
Directive		90/396/EEC, 89/336 (2004/108), 73/23 (90/269), 98/37/EEC, 92/42/EEC				
Conforming to		EN 676				
Certification		CE - 0063 AP6680				

### Reference conditions:

Temperature: 20°C - Pressure: 1013,5 mbar - Altitude: 0 m a.s.l. - Noise was measured in the boiler room behind the burner at a distance of 1 meter.

## FIRING RATES

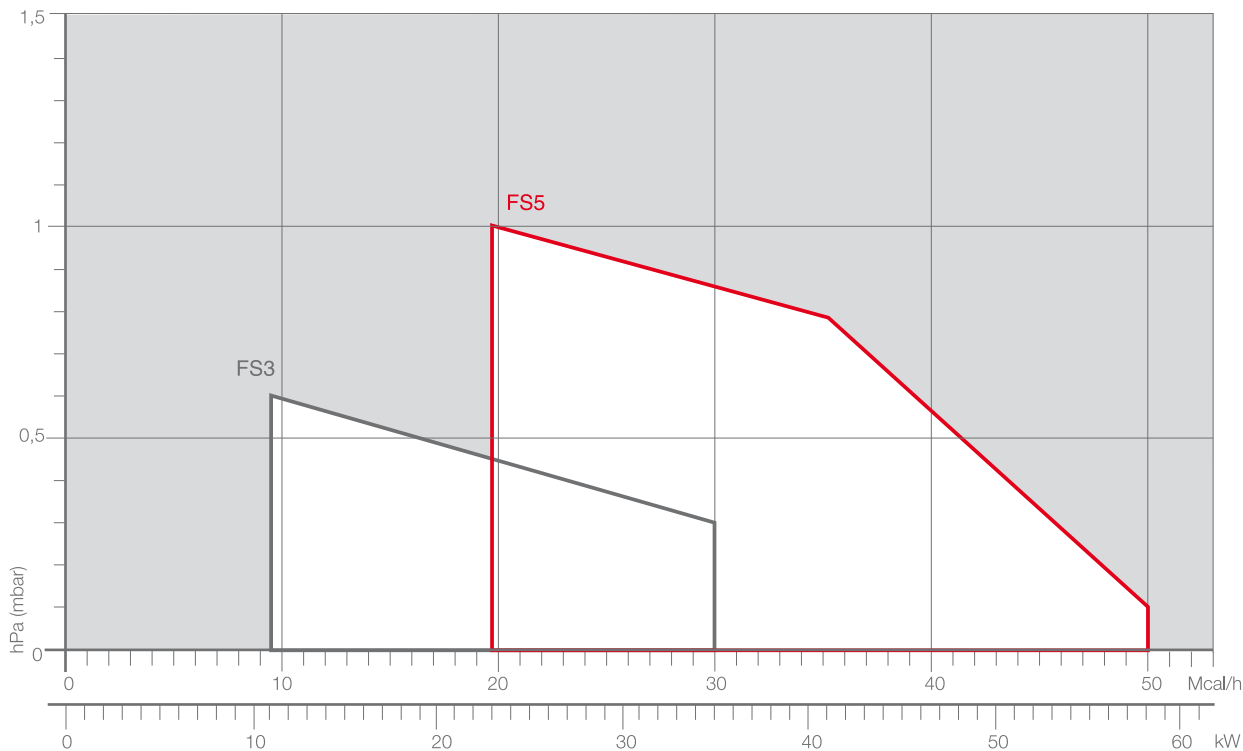

□ Useful working field for choosing the burner

**Test conditions conforming to EN 676:**  
 Temperature: 20°C  
 Pressure: 1013,5 mbar  
 Altitude: 0 m a.s.l.

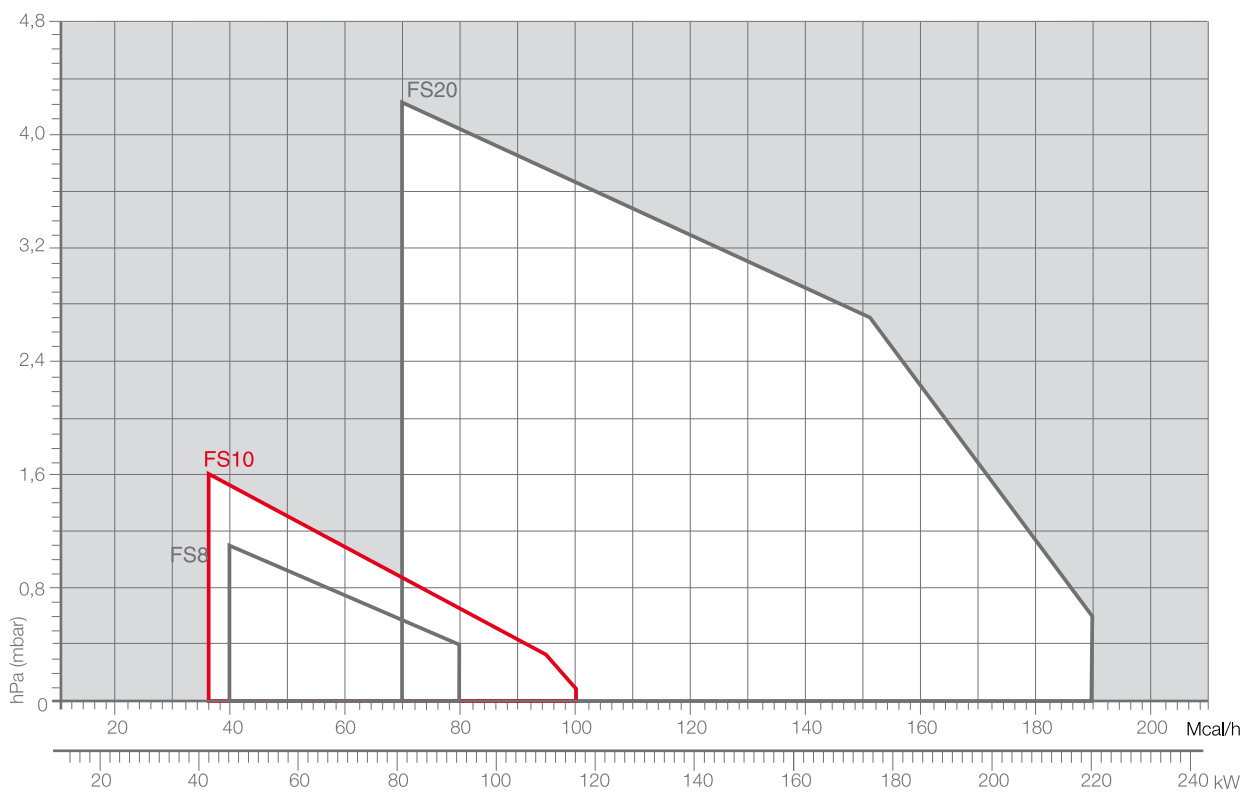



## GAS TRAINS

The burners are set for fuel supply from either the right or left hand sides.

Depending on the gas output and the available pressure in the supply line, you should check the correct gas train to be adapted to the system requirements.

The gas train is Multibloc type, containing the main components in a single unit.

Except for the MBC 65 DLE model, a valve seal control (as accessory) can be fitted to the Multibloc gas trains.

The MBC 65 DLE Multibloc gas train can be fitted only to the left of the burner.



### MBDLE 405 - 407 - 410

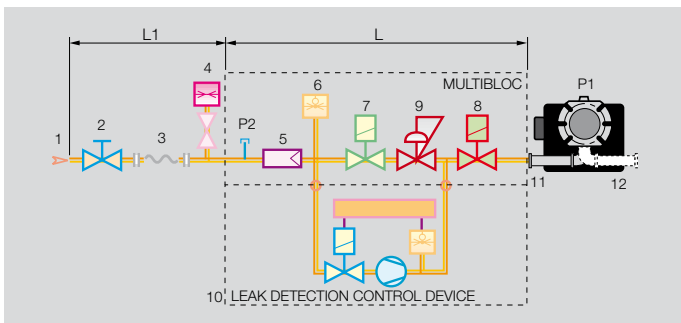

### MBC 65 DLE

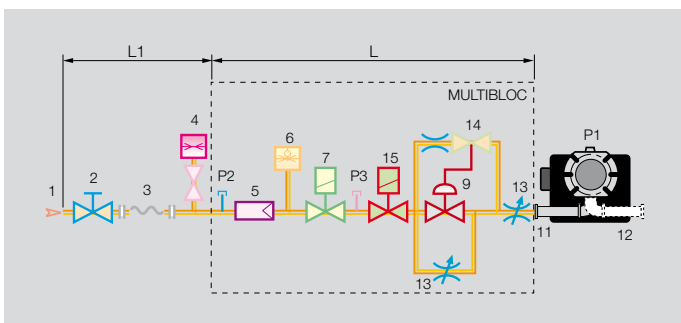

- |    |  |
|----|--|
| 1  | Gas delivery pipe  |
| 2  | Manual valve   |
| 3  | Vibration damping joint                                      |
| 4  | Gas pressure gauge   |
| 5  | Filter   |
| 6  | Gas pressure switch  |
| 7  | Safety solenoid  |
|    | Adjustment solenoid:   |
| 8  | firing delivery adjustment (rapid opening)                   |
|    | maximum delivery adjustment (slow opening)                   |
| 9  | Pressure regulator   |
| 10 | Leak detection control device for valves 7 and 8 (accessory) |
| 11 | Gas train-burner adapter                                     |
| 12 | Burner   |
| 13 | Shutter with adjustment screws                               |
| 14 | Pressure regulator setting device                            |
| 15 | Regulation solenoid  |
| P1 | Combustion head pressure                                     |
| P2 | Upstream pressure from the filter                            |
| P3 | Upstream pressure from the control valve                     |
| L  | Gas train supplied separately                                |
| L1 | To be performed by the installer                             |

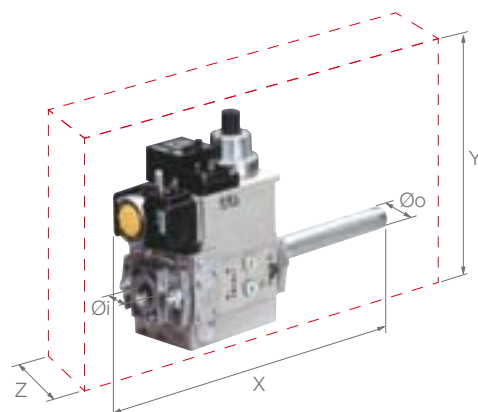
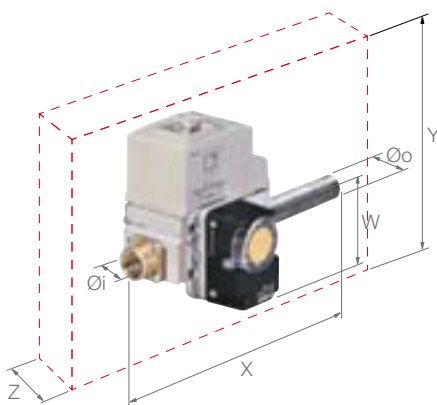

The dimensions of the gas trains vary depending on their construction features.  
The following table shows the dimensions of the gas trains that can be fitted to Riello 40 FS burners, intake and outlet diameters.

MULTIBLOC GAS TRAINS

NAME	CODE	Ø I	Ø O	X mm	Y mm	W mm	Z mm
MBC 65 DLE	3970569	1/2"	1/2"	307	155	31	122
MBDLE 405	3970530	1/2"	1/2"	321	186	46	120
MBDLE 405	3970500	3/4"	3/4"	371	186	46	120
MBDLE 407	3970531	3/4"	3/4"	371	186	46	120
MBDLE 410	3970532	1"	3/4"	405	221	55	145

## PRESSURE DROP DIAGRAM

The diagrams indicate the minimum pressure drop of the burners with the various gas trains that can be matched with them; at the value of these pressure drop add the combustion chamber pressure. The value thus calculated represents the minimum required input pressure to the gas train.

FS3 (NATURAL GAS)

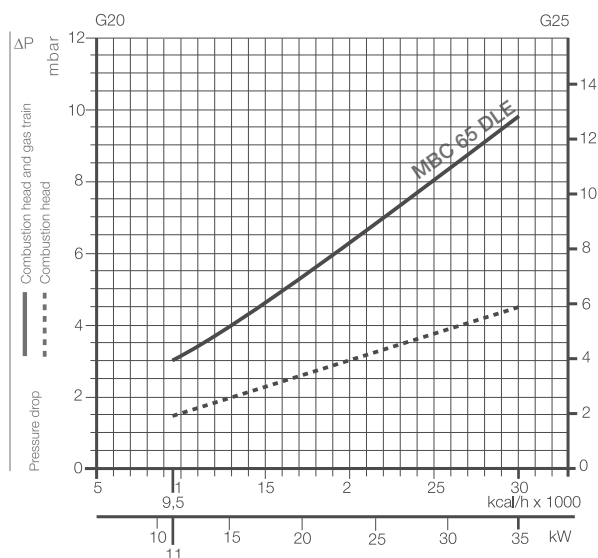

FS3 (LPG)

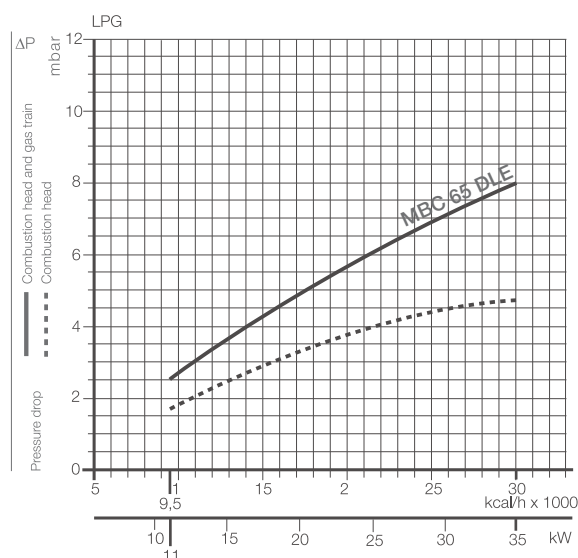

GAS TRAIN	CODE	TERMINAL STRIP	PLUG AND SOCKET
MBC 65 DLE	3970569		•

With installed plug (if the plug is not necessary, remove it in accordance with gas train instruction manual indication).

## FS5 (NATURAL GAS)

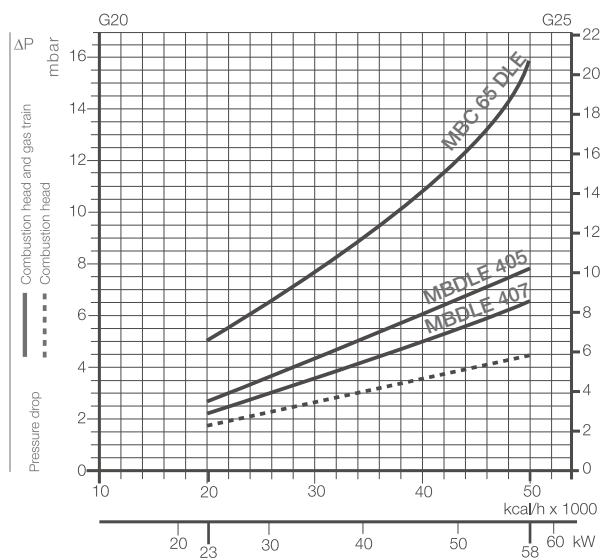

GAS TRAIN	CODE	OUTPUT kW	TERMINAL STRIP	PLUG AND SOCKET
MBC 65 DLE	3970569	-		•
MBDLE 405	3970530	-		•
MBDLE 407	3970531	-		•

## FS5 (LPG)

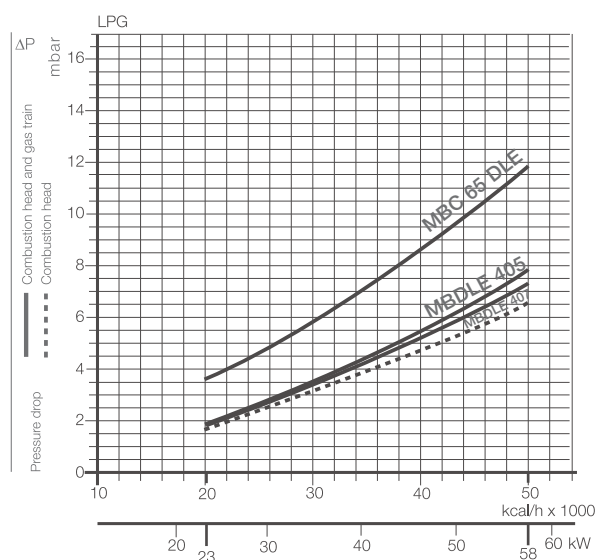

## FS8 (NATURAL GAS)

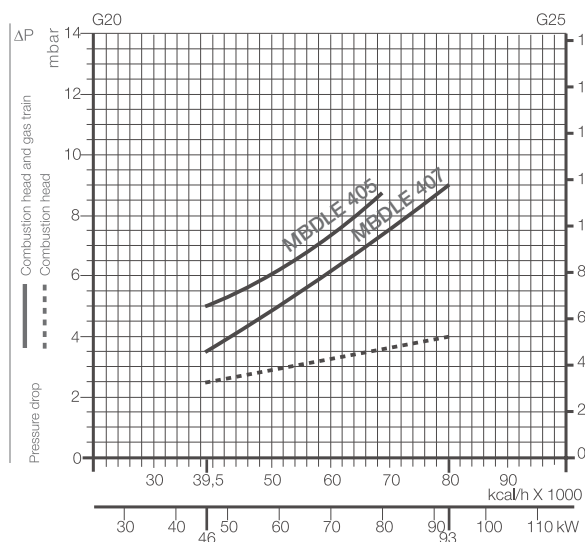

GAS TRAIN	CODE	OUTPUT kW	TERMINAL STRIP	PLUG AND SOCKET
MBDLE 405	3970530	≤ 80 (*)		•
MBDLE 407	3970531	-		•

## FS8 (LPG)

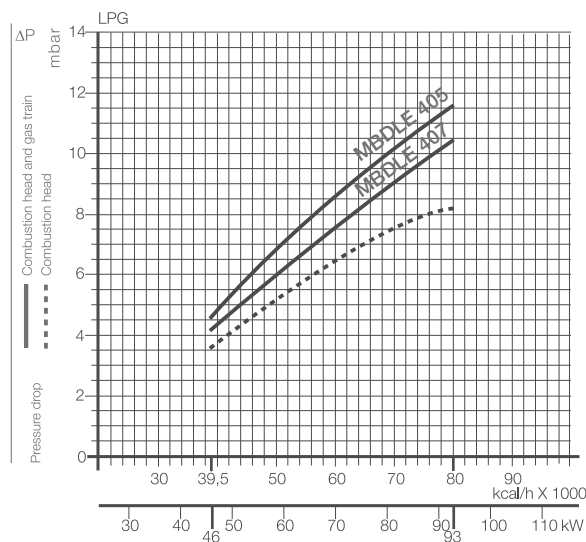

With installed plug (if the plug is not necessary, remove it in accordance with gas train instruction manual indication).

(\*) With natural gas.

### FS10 (NATURAL GAS)

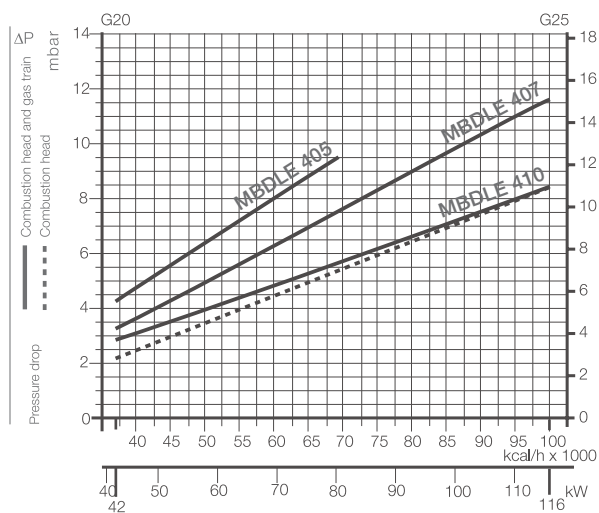

### FS10 (LPG)

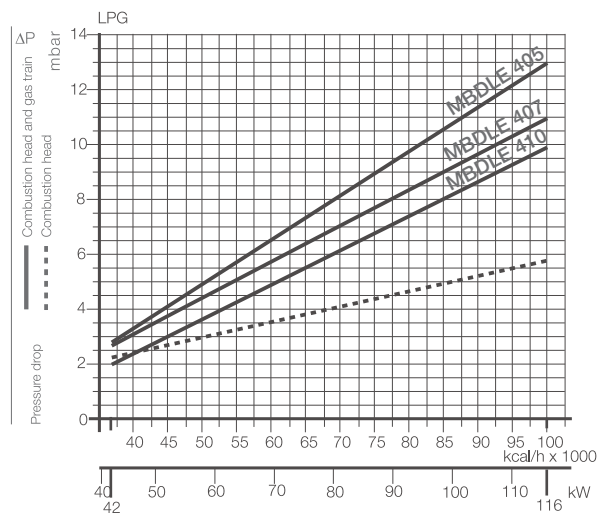

GAS TRAIN	CODE	OUTPUT kW	TERMINAL STRIP	PLUG AND SOCKET
MBDLE 405	3970500	≤ 80 (*)		•
MBDLE 407	3970531	-		•
MBDLE 410	3970532	-		•

### FS20 (NATURAL GAS)

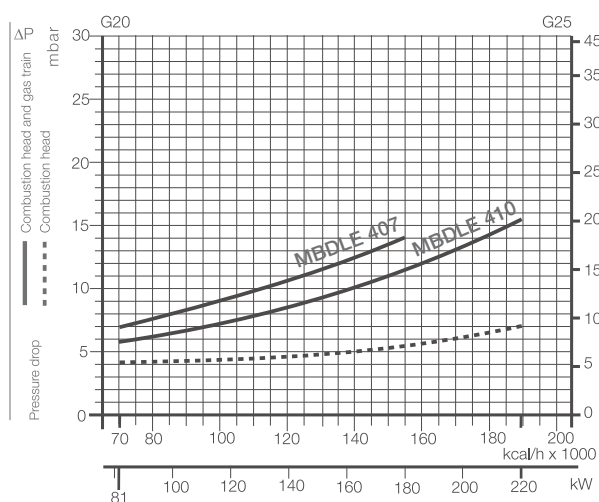

### FS20 (LPG)

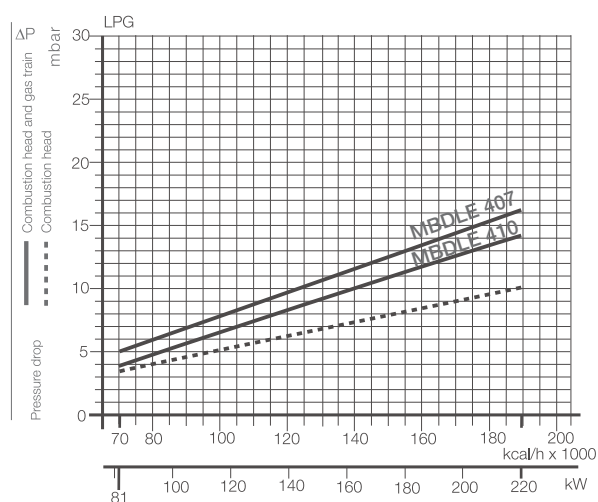

GAS TRAIN	CODE	OUTPUT kW	TERMINAL STRIP	PLUG AND SOCKET
MBDLE 407	3970531	≤ 180 (*)		•
MBDLE 410	3970532	-		•

For pressure levels different from those indicated above, please contact Riello Burners Technical Office.

In LPG plants, Multibloc gas trains do not operate below 0°C.

They are only suitable for gaseous LPG (liquid hydrocarbons destroy the seal materials).

With installed plug (if the plug is not necessary, remove it in accordance with gas train instruction manual indication).

(\*) With natural gas.

## SELECTING THE FUEL SUPPLY LINES

The following diagram enables pressure drop in a pre-existing gas line to be calculated and to select the correct gas train.

The diagram can also be used to select a new gas line when fuel output and pipe length are known. The pipe diameter is selected on the basis of the desired pressure drop. The diagram uses methane gas as reference; if another gas is used, conversion coefficient and a simple formula (on the diagram) transform the gas output to a methane equivalent (refer to figure A). Please note that the gas train dimensions must take into account the back pressure of the combustion chamber during operations.

### Control of the pressure drop in an existing gas line or selecting a new gas supply line.

The methane output equivalent is determined by the formula fig. A on the diagram and the conversion coefficient.

Once the equivalent output has been determined on the delivery scale ( $\dot{V}$ ), shown at the top of the diagram, move vertically downwards until you cross the line that represents the pipe diameter; at this point, move horizontally to the left until you meet the line that represents the pipe length.

Once this point is established you can verify, by moving vertically downwards, the pipe pressure drop of on the bottom scale below (mbar).

By subtracting this value from the pressure measured on the gas

meter, the correct pressure value will be found for the choice of gas train.

**Example:**

- gas used G25
- gas output 9.51 mc/h
- pressure at the gas meter 20 mbar
- gas line length 15 m
- conversion coefficient 0.62 (see figure A)

- equivalent methane output  $\dot{V} = \left[ \begin{matrix} 9.51 \\ 0.62 \end{matrix} \right] = 15.34 \text{ mc/h}$

- once the value of 15.34 has been identified on the output scale ( $\dot{V}$ ), moving vertically downwards you cross the line that represents 1" 1/4 (the chosen diameter for the piping);
- from this point, move horizontally to the left until you meet the line that represents the length of 15 m of the piping;
- move vertically downwards to determine a value of 1.4 mbar in the pressure drop bottom scale;
- subtract the determined pressure drop from the meter pressure, the correct pressure level will be found for the choice of gas train;

- correct pressure = ( 20-1.4 ) = 18.6 mbar

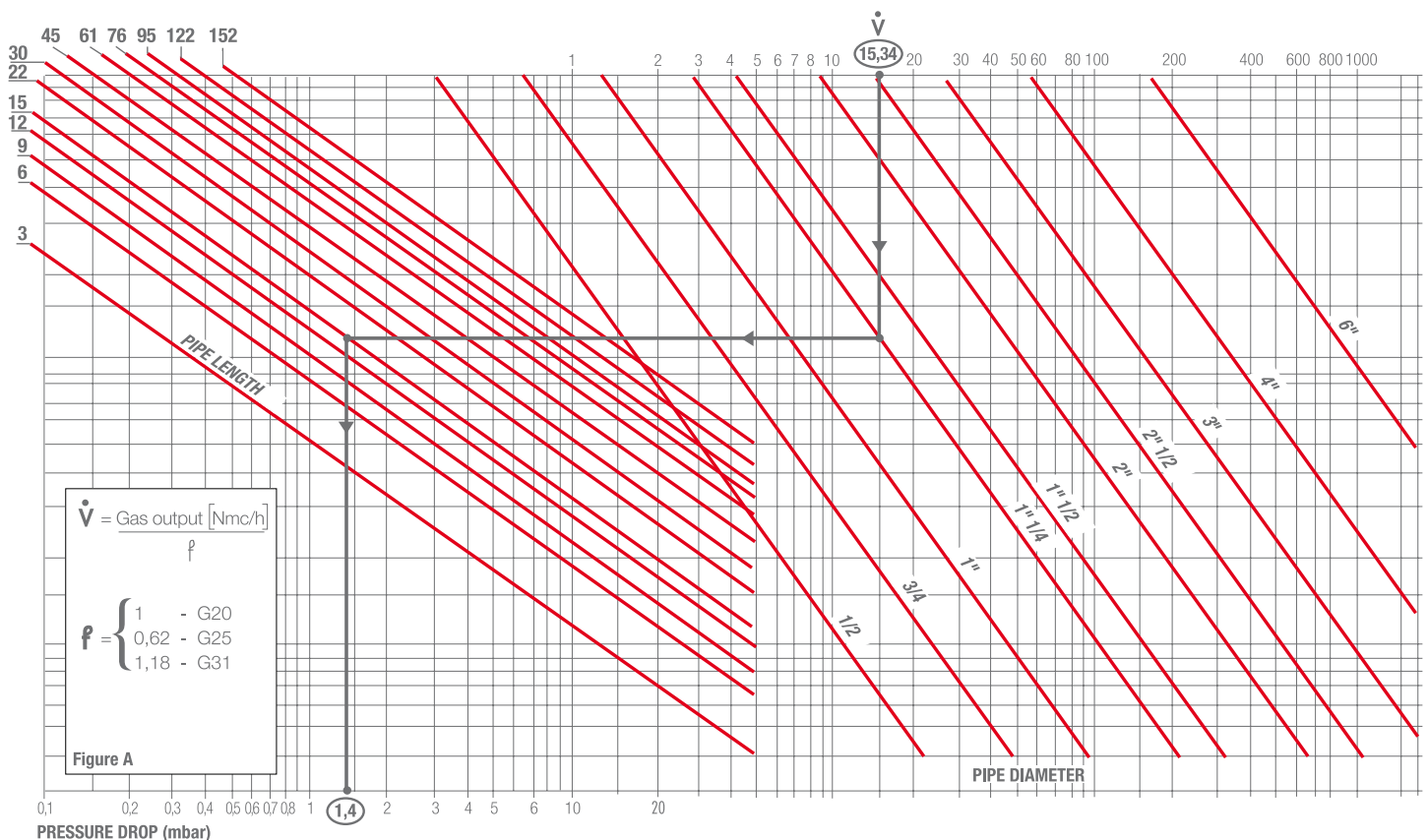



# Ventilation

The different ventilation circuits always ensure low noise levels with high performance of pressure and air delivery, in spite of their compact size.

The burners are fitted with an adjustable air pressure switch, conforming to EN 676 standards.



Air suction

# Combustion Head

The combustion head in Riello 40 FS burners is the result of an innovative design, which allows combustion with low polluting emissions, while being easy to adapt to all the various types of boilers and combustion chambers.

Simple adjustment allows the internal geometry of the combustion head to be adapted to the burner output.



Combustion head.



Flange.

## DIMENSIONS OF THE FLAME

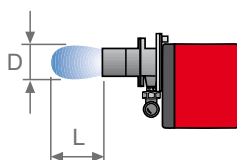

**Example:**  
 Burner thermal output = 350 kW;  
 $L_{\text{flame}}$  (m) = 1,2 m (medium value);  
 $D_{\text{flame}}$  (m) = 0,6 m (medium value)

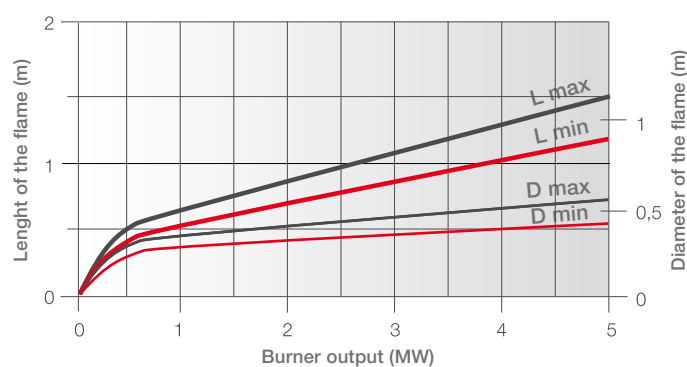



## Operation

### BURNER OPERATION MODE

All these models are one stage operation.

#### “ONE STAGE” OPERATION

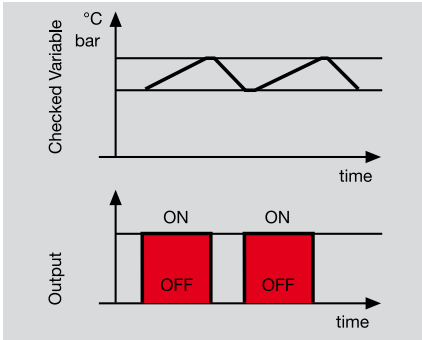

Air adjustment for FS3, FS5 and FS8.



Air adjustment for FS10 and FS20.

The FS3, FS5 and FS8 models are fitted with the new MG 557 microprocessor control panel. For helping the commissioning and maintenance work, there are two main elements:



The lock-out reset button is the central **operating element** for resetting the burner control and for activating / deactivating the diagnostic functions.



The multi-color LED is the central **indication element** for visual diagnosis and interface diagnosis.

Both elements are located under the transparent cover of lock-out reset button, as showed below.

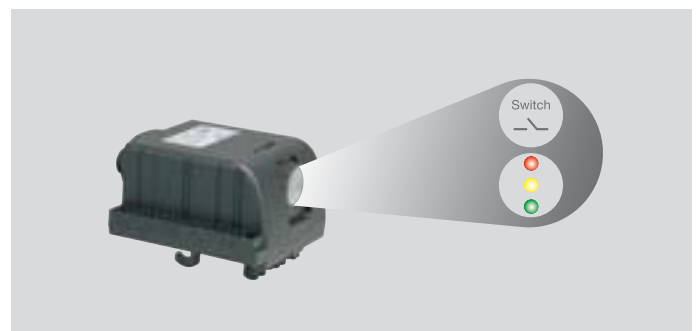

There are two diagnostic choices, for indication of operation and diagnosis of fault cause:

#### VISUAL DIAGNOSIS

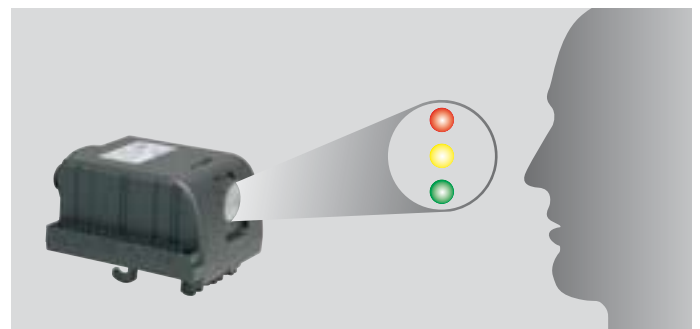

## INTERFACE DIAGNOSIS

By the interface adapter and a PC with dedicated software.

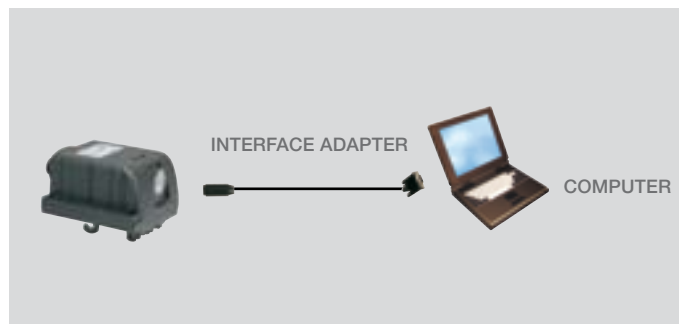

## INDICATION OF OPERATION

In normal operation, the various status are indicated in the form of colour codes according to the table below.

COLOR CODE TABLE	
Operation status	Color code
Stand-by	●
Pre-purging	●
Ignition phase	●
Flame OK	●
Post purge	●
Undervoltage, built-in fuse	●
Fault, alarm	●
Flame simulation	●

● LED off

## DIAGNOSIS OF FAULT CAUSES

After lock-out has occurred, the red signal lamp is steady on. In this status, the visual fault diagnosis according to the error code table can be activated by pressing the lock-out reset button for > 3 seconds.

The interface diagnosis (with adapter) can be activated by pressing again the lock-out button for > 3 seconds.

Example of flashes sequence:

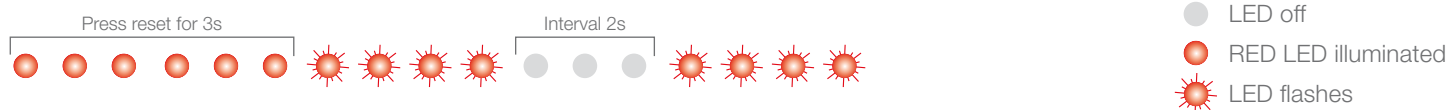

## ERROR CODE TABLE

POSSIBLE CAUSE OF FAULT	FLASH CODE
The flame does not stabilise at the end of the safety time:	<ul style="list-style-type: none"> <li>- faulty ionisation probe</li> <li>- faulty or soiled gas valves</li> <li>- neutral/phase exchange</li> <li>- faulty ignition transformer</li> <li>- poor burner regulation (insufficient gas)</li> </ul> ● 2x flashes
Min. air pressure switch does not close or is already closed before the limit thermostat closed:	<ul style="list-style-type: none"> <li>- air pressure switch faulty</li> <li>- air pressure switch incorrectly regulated</li> </ul> ● 3x flashes
Presence of flame:	<ul style="list-style-type: none"> <li>- in stand-by position after heat demand</li> <li>- during pre-purging</li> </ul> ● 4x flashes
Loss air pressure:	<ul style="list-style-type: none"> <li>- during pre-purging</li> <li>- during safety time or operations</li> </ul> ● 6x flashes
Loss of flame 4 times during operations after 3 attempts of re-cycle:	<ul style="list-style-type: none"> <li>- poor burner regulation (insufficient gas)</li> <li>- faulty or soiled gas valves</li> <li>- short circuit between ionisation probe and earth</li> <li>- faulty ionisation probe</li> </ul> ● 7x flashes

The FS10 and FS20 models are also fitted with the RMG 88.620 A2 microprocessor control panel for the supervision during intermittent operation.

For helping the commissioning and maintenance work, there are two main elements:

 The lock-out reset button is the central **operating element** for resetting the burner control and for activating / deactivating the diagnostic functions.

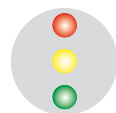
 The multi-color LED is the central **indication element** for visual diagnosis and interface diagnosis.

Both elements are located under the transparent cover of lock-out reset button, as showed below.



There are two diagnostic choices, for indication of operation and diagnosis of fault cause:

## VISUAL DIAGNOSIS

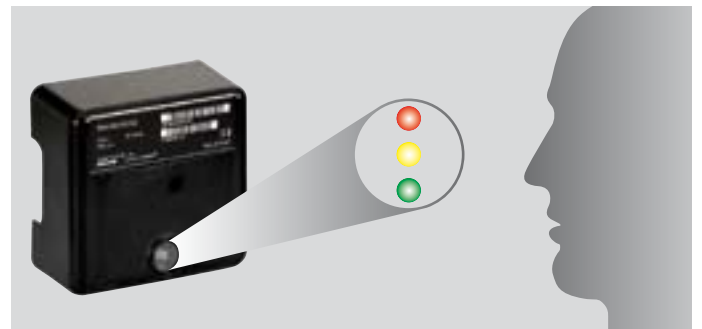

## INTERFACE DIAGNOSIS

By the interface adapter and a PC with dedicated software or by a predisposed flue gas analyzer (see paragraph accessories).

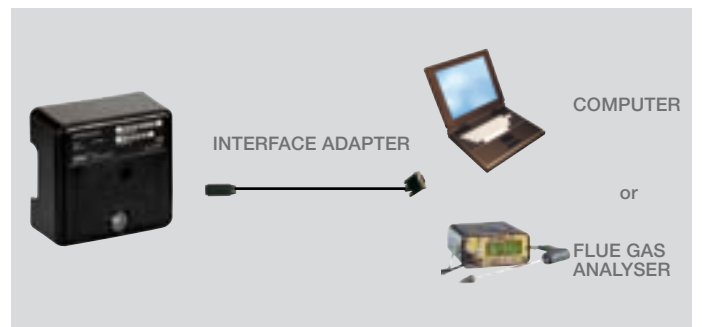

## INDICATION OF OPERATION

In normal operation, the various status are indicated in the form of colour codes according to the table below.

The interface diagnosis (with adapter) can be activated by pressing the lock-out button for > 3 seconds.

COLOR CODE TABLE							
Operation status	Color code table						
Stand-by	●	●	●	●	●	●	●
Pre-purging	●	●	●	●	●	●	●
Ignition phase	●	●	●	●	●	●	●
Flame OK	●	●	●	●	●	●	●
Poor flame	●	●	●	●	●	●	●
Undervoltage, built-in fuse	●	●	●	●	●	●	●
Fault, alarm	●	●	●	●	●	●	●
Flame simulation	●	●	●	●	●	●	●

● LED off

## DIAGNOSIS OF FAULT CAUSES

After lock-out has occurred, the red signal lamp is steady on. In this status, the visual fault diagnosis according to the error code table can be activated by pressing the lock-out reset button for > 3 seconds.

The interface diagnosis (with adapter) can be activated by pressing again the lock-out button for > 3 seconds.

The flashing of red LED are a signal with this sequence:

(e.g. signal with n° 3 flashes – faulty air pressure monitor)



## ERROR CODE TABLE

POSSIBLE CAUSE OF FAULT	FLASH CODE
No establishment of flame at the end of safety time: - faulty or soiled fuel valves - faulty or soiled flame detector - poor adjustment of burner, no fuel - faulty ignition equipment	● 2x flashes
Faulty air pressure monitor	● 3x flashes
Simulation of flame on burner start up	● 4x flashes
Loss of flame during operation: - faulty or soiled fuel valves - faulty or soiled flame detector - poor adjustment of burner	● 7x flashes
Wiring error or internal fault	● 10x flashes

## START UP CYCLE

### FS3 - FS5 - FS8

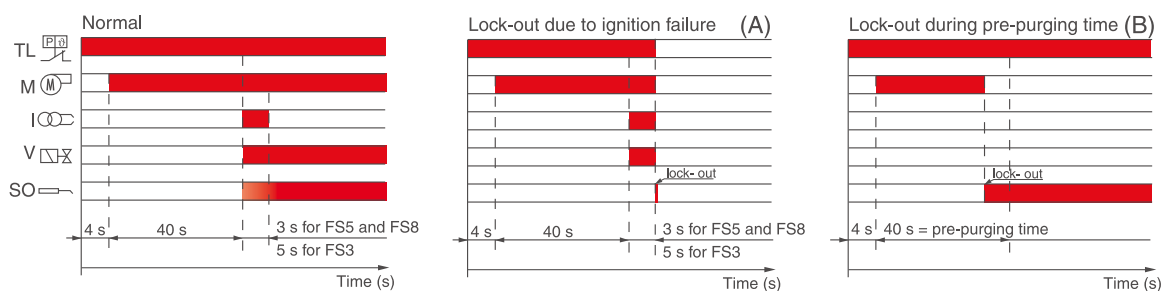

(A) - (B) Lock-out is shown by a led on the appliance.

### Correct operation for FS3, FS5 and FS8 models:

- 0s The burner begins the ignition cycle
- 0s-4s The control box waits still after the heat request
- 4s-44s Pre-purging time with start of the fan motor
- 44s-47s FS5 and FS8 safety time as total ignition time
- 44s-49s FS3 safety time as total ignition time.

### Lock-out due to ignition failure

If the flame does not light within the safety limit time (3s for FS 5 and FS8; 5s for FS3) the burner locks-out.

## FS10 - FS20

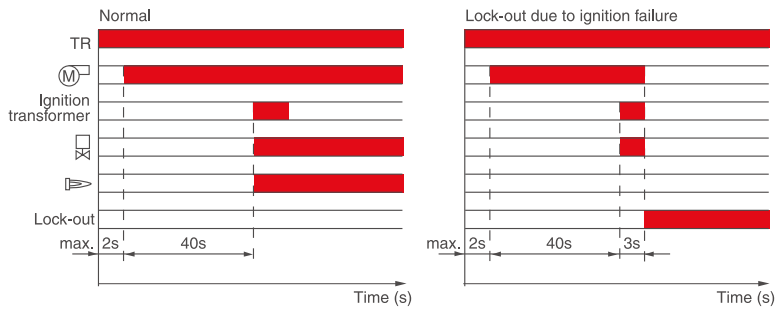

### Correct operation for FS10 and FS20 models:

- 0s The burner begins the ignition cycle
- 0s-2s Safety time
- 2s-40s Pre-purge with the air damper open
- 40s Ignition.

### Lock-out due to ignition failure

If the flame does not light within the safety limit (3s) the burner locks-out. When the flame-failure occurs during working, shut down takes place within one second.



## Burner Wiring

Electrical connections must be made by qualified and skilled personnel in conformity with the local regulations in force.



FS3 is fitted with terminal strip: FS5, FS10 and FS20 are fitted with 7 and 6 pole sockets, FS8 is available in both the configurations.



Control box fitted with an ignition transformer in FS3, FS5 and FS8 models.



In FS10 and FS20 models the control box is separated from the ignition transformer.

## ONE STAGE OPERATION

### FS3 - FS5 - FS8

<b>h1</b>	Hour counter (230V - 0,1A max.)
<b>PG</b>	Minimum gas pressure switch
<b>SB</b>	Lock-out led (230V - 0,5A max.)
<b>TL</b>	Limit thermostat
<b>TS</b>	Safety thermostat
<b>T6A</b>	Fuse
<b>V1</b>	Adjustment valve
<b>VS</b>	Safety valve
<b>XP6</b>	6 pole socket
<b>XP7</b>	7 pole socket

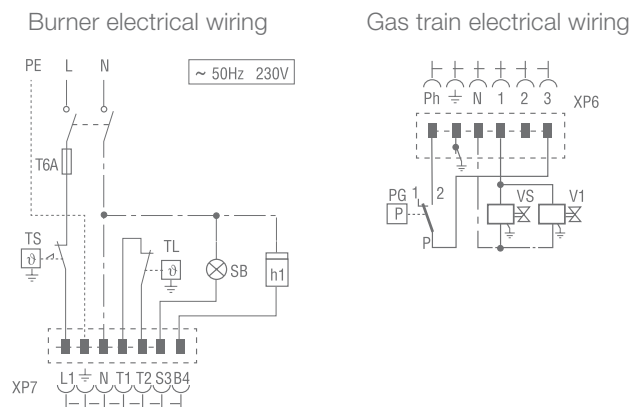

### FS10 - FS20

<b>XP6</b>	6 pole socket
<b>XP7</b>	7 pole socket
<b>X6</b>	6 pin plug
<b>X7</b>	7 pin plug
<b>B4</b>	Working signal
<b>h1</b>	Hour counter
<b>PG</b>	Minimum gas pressure switch
<b>S3</b>	Remote lock-out signal (230V - 0,5A max.)
<b>TL</b>	Limit thermostat
<b>TS</b>	Safety thermostat
<b>V10</b>	Safety valve
<b>V11</b>	Adjustment valve
<b>T6A</b>	Fuse

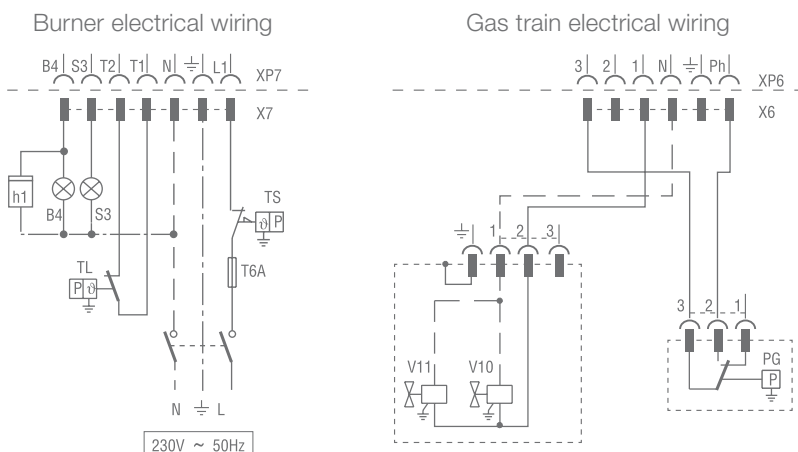

### ELECTRICAL WIRING WITH GAS LEAK CONTROL DEVICE (DUNGS VPS 504)

<b>XP6</b>	6 pole socket
<b>XP7</b>	7 pole socket
<b>X6</b>	6 pin plug
<b>X7</b>	7 pin plug
<b>B4</b>	Working signal
<b>h1</b>	Hour counter
<b>PG</b>	Minimum gas pressure switch
<b>S3</b>	Remote lock-out signal (230V - 0,5A max.)
<b>TL</b>	Limit thermostat
<b>TS</b>	Safety thermostat
<b>V10</b>	Safety valve
<b>V11</b>	Adjustment valve
<b>T6A</b>	Fuse

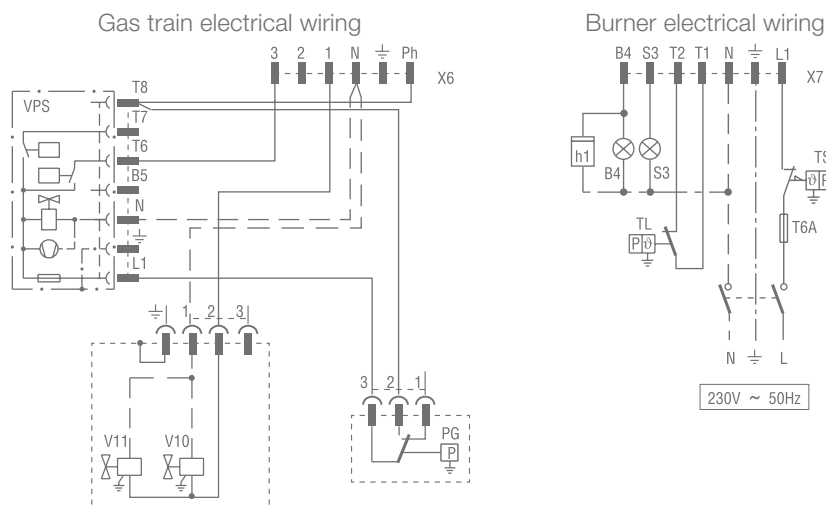

The following table shows the supply lead sections and the type of fuse to be used.

MODEL	V	F (A)	L (mm <sup>2</sup> )
▶ FS3	230	T6	1
▶ FS5	230	T6	1
▶ FS8	230	T6	1

MODEL	V	F (A)	L (mm <sup>2</sup> )
▶ FS10	230	T6	1
▶ FS20	230	T6	1

V = Electrical supply    F = Fuse    L = Lead section

## Emissions

The emission data have been measured in the various models at maximum output, in conformity with EN 676 standard.

Special attention has been paid to noise reduction in the FS3 model. The model is fitted with sound-proofing material inside the cover.

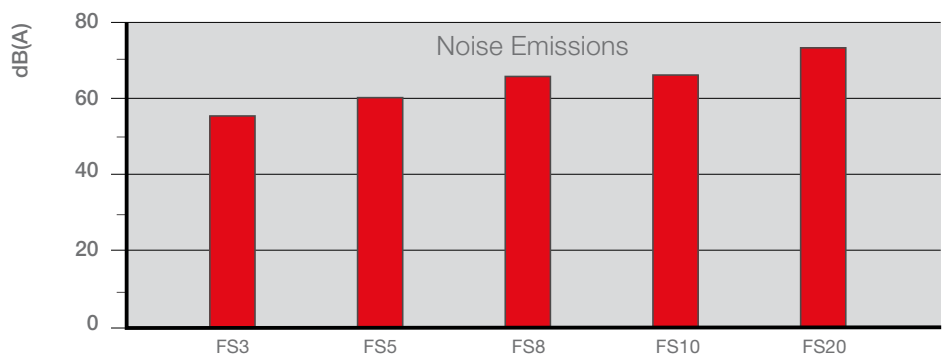
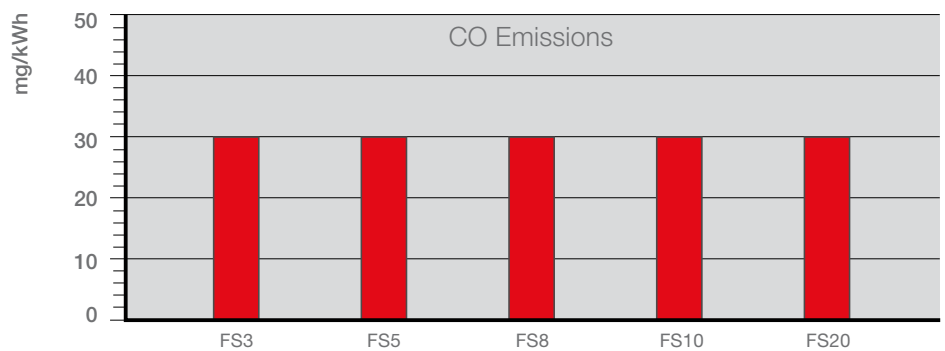
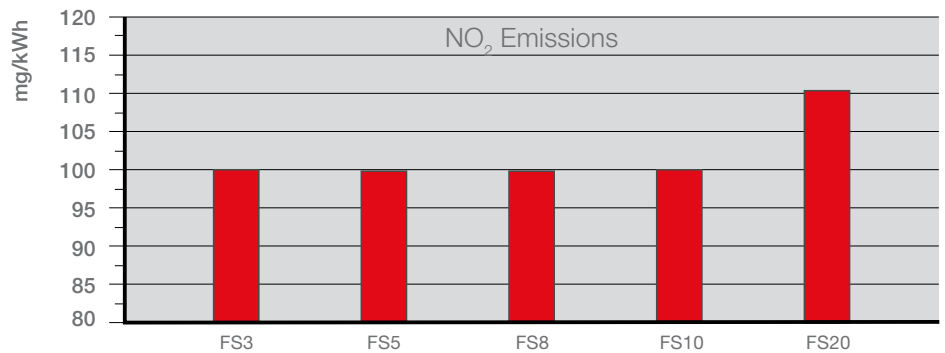



# Overall Dimensions (mm)



These models are distinguished by their reduced size, in relation to the outputs achieved, which means they can be fitted to any boiler actually on the market.

## BURNERS

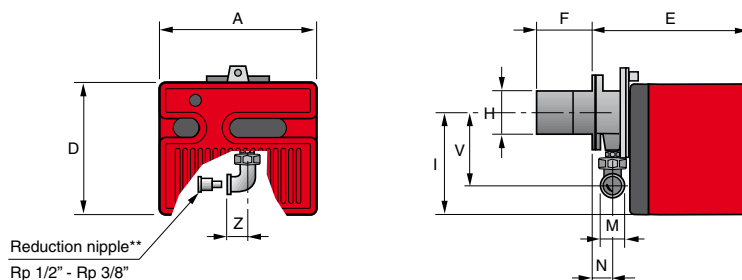

MODEL	A	D	E	F	H	I	M	N	V	Z
▶ FS3	252	215	230	100	91	165	Rp 3/8" *	37	132	25
▶ FS5	272	233	295	100	91	180	Rp 1/2"	48	138	28
▶ FS8	305	262	347	110	105	204	Rp 3/4"	61	142	33
▶ FS10	305	262	346	110	105	204	Rp 3/4"	61	142	33
▶ FS20	350	298	389	120	125	230	Rp 3/4"	67	152	33

\* With reduction nipple.

\*\* Standard equipment on R40 FS3.

## BURNER - BOILER MOUNTING FLANGE

FS3 - FS5 - FS8 - FS10

FS20

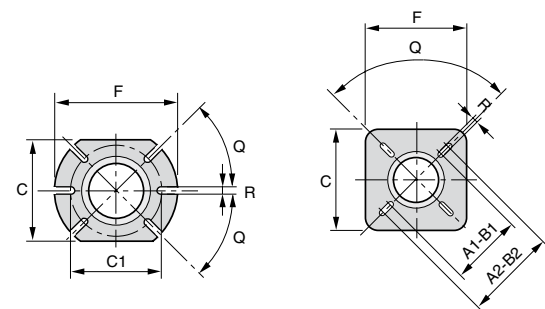

MODEL	A1	A2	B1	B2	C	C1	F	Q	R
▶ FS3	-	-	-	-	140	130	170	45	10
▶ FS5	-	-	-	-	140	130	170	45	10
▶ FS8	-	-	-	-	160	130	185	45	11
▶ FS10	-	-	-	-	160	130	185	45	11
▶ FS20	155	200	155	200	170	-	170	90	11

## PACKAGING

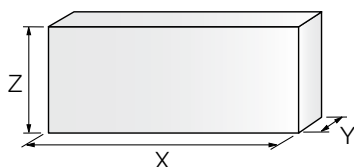

MODEL	X	Y	Z	kg
▶ FS3	375	335	310	9,5
▶ FS5	445	355	335	11
▶ FS8	483	495	330	13,6
▶ FS10	483	495	330	17
▶ FS20	535	535	375	20

## Installation Description

Installation, start up and maintenance must be carried out by qualified and skilled personnel. The burner is set in factory on standard calibration (minimum output), if necessary adjustments can be made on the basis of the maximum output of the boiler. All operations must be performed as described in the technical handbook supplied with the burner.

### **BURNER SETTING**

The air damper position can be easily adjusted removing the burner cover.



Head setting is easy and aided by a graduated scale, a test point allows reading the air pressure in the combustion head.



Riello 40 FS burners are fitted with an air pressure switch which, in accordance with EN 676 standards, can be adjusted by the installer using a graduated selector, on the basis of the effective working conditions.



### **BURNER MAINTENANCE**

Maintenance is easily solved because the combustion head can be disassembled without having to remove the burner from the boiler.

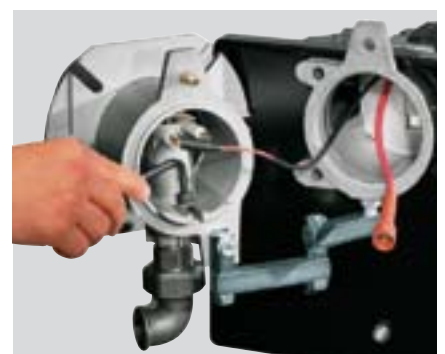



## Remote reset control kit for MG 557/3/5 control box

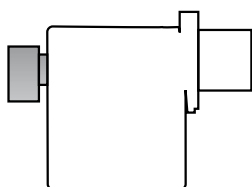

The MG 557 control box can be remotely released using an electric command kit. This kit must be installed in conformity with the local authority.

BURNER	KIT CODE
▶ FS3 - FS5 - FS8	3002750

## Extended head kit

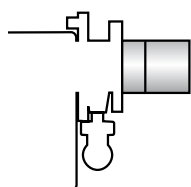

Burners “standard head” can be transformed into “extended head” versions by using the special kit. Here the KITS available for the various burners are listed, showing the original and the extended lengths.

BURNER	STANDARD HEAD LENGTH (mm)	EXTENDED HEAD LENGTH (mm)	KIT CODE
▶ FS3 - FS5	100	125	3000820
▶ FS8 - FS10	110	170	3000864
▶ FS8	110	278	3000920
▶ FS20	120	280	3000873

## End cone with turbulator disk



BURNER	PROJECTION (mm)	KIT CODE
▶ FS5	+15	3000916
▶ FS8	+18	3000917
▶ FS10	+18	3000918
▶ FS20	+23	3000919

## LPG kit

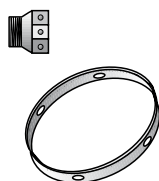

For burning LPG gas, a special kit is available to be fitted to the combustion head on the burner as shown in the following table.

BURNER	KIT CODE FOR STANDARD HEAD	KIT CODE FOR EXTENDED HEAD
▶ FS3	3000881	3000881
▶ FS5	3000882	3000882
▶ FS8	3000927	3000927
▶ FS10	3000884	3000884
▶ FS20	3000886	3000886

## 7-pin plug kit

If necessary a 7-pin plug kit is available (in packaging of n. 5 pieces).

BURNER	KIT CODE
▶ FS3 - FS5 - FS8 - FS10 - FS20	3000945

## Town gas kit

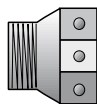

BURNER	KIT CODE
▶ FS3	3000888
▶ FS5	3000889
▶ FS8	3000890
▶ FS10	3000891
▶ FS20	3000893

## PC interface kit



To connect the flame control panel to a personal computer for the transmission of operation, fault signals and detailed service information, an interface adapter with PC software are available.

BURNER	KIT CODE
▶ FS3 - FS5 - FS8	3002731
▶ FS10 - FS20	3002719

## Ground fault interrupter kit



A "Ground fault interrupter kit" is available as a safety device in case of electrical system fault. It is supplied with burners with pin plug.

BURNER	KIT CODE
▶ FS5 - FS8 - FS10 - FS20	3001180

## Continuous ventilation kit for RMG control box

If the burner requires continuous ventilation in the stages without flame, a special kit is available as given in the following table.

BURNER	KIT CODE
▶ FS10 - FS20	3010094

# Gas Train Accessories

## Seal control kit



To test the valve seals on the gas train, (except for the model with Multibloc MBC 65 DLE) a special "seal control kit" is available.

BURNER	KIT CODE
► FS5 - FS8 - FS10 - FS20	3010123

## BALANCED FLUE VERSION

The R40 series balanced flue gas burner has been specifically designed to meet the increasing trend towards the use of balanced flue, otherwise known as room sealed appliances, which avoid the necessity of having a chimney to discharge the products of combustion.

Balanced flue products are completely sealed from the environment in which they are installed, drawing air for combustion directly from the outside, thereby ensuring no unwelcome smells from the combustion.

As a result of the burner components being completely enclosed this provides an additional benefit of low sound levels.

This version is available for FS3 and FS5 only.



Riello 40 FS Balanced Flue version.

### OVERALL DIMENSIONS (mm)

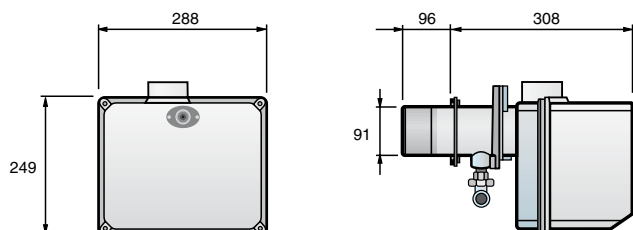

## Specification

### DESIGNATION OF SERIES

A special index guides your choice of boiler from the various models available in the FS series. Below is a clear and detailed specification description of the product.

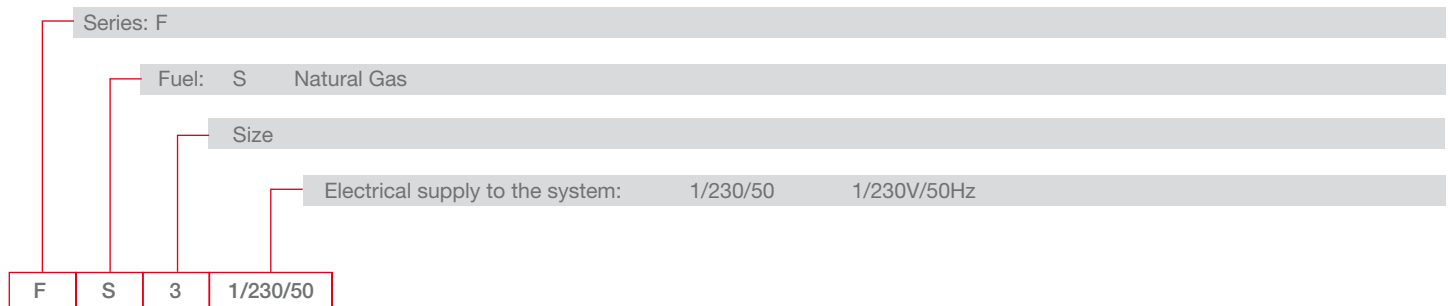

### AVAILABLE BURNER MODELS

FS3	1/230/50
FS5	1/230/50
FS8	1/230/50
FS10	1/230/50
FS20	1/230/50

### PRODUCT SPECIFICATION

#### Burner

Monoblock, gas burners, completely automatic, with one stage settings fitted with:

- Fan with forward curve blades
- Cover lined with sound-deadening material
- Metallic and fixed air damper with adjustment
- Single phase electric motor 230 V, 50 Hz
- Combustion head fitted with:
  - stainless steel head cone, resistant to high temperatures
  - ignition electrodes
  - ionisation probe
  - gas distributor
  - flame stability disk
  - flame inspection window
- Adjustable air pressure switch, with graduated selector, to guarantee burner lock out in the case of insufficient combustible air
- Microprocessor-based flame control panel, with diagnostic functions
- IP X0D electric protection level.

#### Gas train

Fuel supply line in the Multibloc configuration, fitted with:

- Filter
- Pressure stabiliser
- Minimum gas pressure switch
- Safety valve
- Single stage working valve with ignition gas output regulator.

**Approval:**

- EN 676 standard.

**Conforming to:**

- 90/396/EEC (gas)
- 89/336 (2004/108) EC directive (electromagnetic compatibility)
- 73/23 (2006/95) EC directive (low voltage)
- 92/42/EEC (efficiency)
- 98/37/EEC (machines).

**Standard equipment:**

- Flange insulation screen
- Screws and nuts for fixing the flange to the boiler
- 7-pole socket
- Hinge
- Reduction nipple Rp 1/2" - Rp 3/8" (for R40 FS3 only)
- Grommet
- Instruction handbook for installation, use and maintenance
- Spare parts catalogue.

**Available accessories to be ordered separately:**

- Remote reset kit for MG 557/3/5 control box
- Extended head kit
- End cone with turbulator disk
- LPG kit
- 7-pin plug kit
- Town gas kit
- PC interface kit
- Ground fault interrupter kit
- Continuous ventilation kit for RMG control box
- Balanced flue version
- Seal control kit.

**RIELLO** s.p.A.

Via Ing. Pilade Riello, 5  
37045 Legnago (VR) Italy

Tel. +39.0442.630111 - Fax +39.0442.21980

[www.rielloburners.com](http://www.rielloburners.com) - [info@rielloburners.com](mailto:info@rielloburners.com)

Since the Company is constantly engaged in the production improvement, the aesthetic and dimensional features, the technical data, the equipment and the accessories can be changed.  
This document contains confidential and proprietary information of RIELLO S.p.A. Unless authorised, this information shall not be divulged, nor duplicated in whole or in part.



Riello Burners is a brand of Riello Group.