

TWO STAGE DUAL FUEL BURNERS

▶ **RLS SERIES**

| | |
|------------------|-------------------|
| ▶ RLS 28 | 100/163 ÷ 325 kW |
| ▶ RLS 38 | 116/232 ÷ 442 kW |
| ▶ RLS 50 | 145/290 ÷ 581 kW |
| ▶ RLS 70 | 232/465 ÷ 814 kW |
| ▶ RLS 100 | 349/698 ÷ 1163 kW |
| ▶ RLS 130 | 465/930 ÷ 1395 kW |



The RLS series of burners covers a firing range from 163 to 1395 kW, and it has been designed for use in low or medium temperature hot water boilers, hot air or steam generators, diathermic oil boilers.

Operation is "two stage"; the burners are fitted with an electronic device STATUS PANEL, which supplies complete diagnostic functions: hour meter, ignition meter, identification of trouble shooting.

Optimisation of sound emissions is guaranteed by the use of fans with reverse curve blades and sound deadening material incorporated in the air suction circuit.

The elevated performance of the fans and combustion head guarantee flexibility of use and excellent working at all firing rates.

The exclusive design ensures reduced dimensions, simple use and maintenance. A wide range of accessories guarantees elevated working flexibility.

TECHNICAL DATA

| Model | | | ▼ RLS 28 | ▼ RLS 38 | ▼ RLS 50 | ▼ RLS 70 | ▼ RLS 100 | ▼ RLS 130 |
|---------------------------------|--------------------------|---------------------------|--|-------------|-------------|-----------------------------------|--------------|---------------|
| Operation | | | Two stage | | | | | |
| Modulating ratio at max. output | | | 2:1 | | | | | |
| Servomotor | type | | LKS 210 - 08 | | | LKS 210 -10 | | |
| | run time | s | 5 | | | | | |
| Heat output | kW | | 100/163-325 | 116/232-442 | 145/290-581 | 232/465-814 | 349/698-1163 | 465/930-1395 |
| | Mcal/h | | 86/140-303 | 100/200-380 | 125/249-500 | 200/400-700 | 300/600-1000 | 400/800-1200 |
| Working temperature | | °C min/max | 0/40 | | | | | |
| Light oil | Net calorific value | kWh/kg | 11,8 | | | | | |
| | Viscosity at 20°C | mm ² /s (cSt) | 4-6 | | | | | |
| | Delivery | kg/h | 8/14-28 | 10/20-37 | 12/25-49 | 20/39-69 | 30/59-99 | 39/79-118 |
| | Max temperature | °C | 60 | | | | | |
| Pump | type | | AL 65B | | | AJ 6CC | | |
| | delivery | kg/h | 63 (at 15 bar) | | | 134 (at 20 bar) | | |
| Atomised pressure | | bar | 12 | | | | | |
| G20 | Net calorific value | kWh/Nm ³ | 10 | | | | | |
| | Density | kg/Nm ³ | 0,71 | | | | | |
| | Delivery | Nm ³ /h | 10/16-32,5 | 12/23-44 | 14,5/29-58 | 23/46,5-81 | 35/70-116 | 46,5/93-139,5 |
| G25 | Net calorific value | kWh/Nm ³ | 8,6 | | | | | |
| | Density | kg/Nm ³ | 0,78 | | | | | |
| | Delivery | Nm ³ /h | 12/19-38 | 13/27-51 | 17/33-68 | 27/54-95 | 41/81-135 | 54/108-162 |
| LPG | Net calorific value | kWh/Nm ³ | 25,8 | | | | | |
| | Density | kg/Nm ³ | 2,02 | | | | | |
| | Delivery | Nm ³ /h | 4/6-13 | 4/9-17 | 6/11-23 | 9/18-32 | 14/27-45 | 18/36-54 |
| Fan | | type | Centrifugal - with reverse curve blades | | | | | |
| Air temperature | | max °C | 60 | | | | | |
| Electrical supply | | Ph / Hz / V | 1/50/230 (±10%) | | | 3N/50/230-400 (±10%) | | |
| Auxiliary electrical supply | | Ph / Hz / V | 1/50/230 (±10%) | | | | | |
| Control box | | type | LFL 1.333 | | | | | |
| Total electrical power | | kW | 0,53 | 0,76 | 0,91 | 1,8 | 2,2 | 3 |
| Auxiliary electrical power | | kW | 0,19 | 0,25 | 0,17 | 0,33 | 0,33 | 0,43 |
| Protection level | | IP | 44 | | | | | |
| Fan electrical motor power | | kW | 0,25 | 0,42 | 0,65 | 1,1 | 1,5 | 2,2 |
| Rated fan motor current | | A | 2,1 | 2,9 | 3 -1,7 | 4,8 - 2,8 | 5,9 - 3,4 | 8,8 - 5,1 |
| Fan motor start current | | A | 4,8 | 11 | 13,8-8 | 22,6 -13,2 | 29,5 -17 | 52,8 - 30,6 |
| Fan motor protection level | | IP | 44 | | | 55 | 54 | |
| Pump electric motor power | | kW | 0,09 | | | 0,37 | | |
| Rated pump motor current | | A | 0,8 | | | 2,4 | | |
| Pump motor start current | | A | - | - | - | - | - | - |
| Pump motor protection level | | IP | 44 | | | | | |
| Ignition transformer | | V1- V2 | 230 V - 2 x 5 kV | | | | | |
| | | I1 - I2 | 1,9 A - 30 mA | | | | | |
| Working | | | Intermittent (at least one stop every 24h) | | | | | |
| Sound pressure | | dBA | 68 | 70 | 72 | 74 | 77,5 | 80 |
| Sound power | | W | - | - | - | - | - | - |
| Light oil | CO emissions | mg/kWh | < 20 | | | | | |
| | Grade of smoke indicator | N° Bacharach | < 1 | | | | | |
| | CxHy emissions | mg/kWh | < 10 | | | | | |
| | NOx emissions | mg/kWh | < 190 | | | | | |
| G20 | CO emissions | mg/kWh | < 15 | | | | | |
| | NOx emissions | mg/kWh | < 80 | | | | | |
| Directive | | | 90/396/EC - 89/336 (2004/108) EC - 73/23/EC - 92/42/EC | | | | | |
| Conforming to | | | EN 267 - EN 676 | | | | | |
| Certifications | | | CE 0063 AR 4637 | | | CE 0063 AS 4863 - DIN 5G 835/97 M | | |

Reference conditions:

Ambient temperature: 20°C

Pressure: 1000 mbar

Altitude: 100 m a.s.l.

Sound pressure level measured in manufacturers combustion laboratory, with burner operating on test boiler and at maximum rated output

Since the Company is constantly engaged in the production improvement, the aesthetic and dimensional features, the technical data, the equipment and the accessories can be changed.

This document contains confidential and proprietary information of RIELLO S.p.A. Unless authorised, this information shall not be divulged, nor duplicated in whole or in part.

FIRING RATES

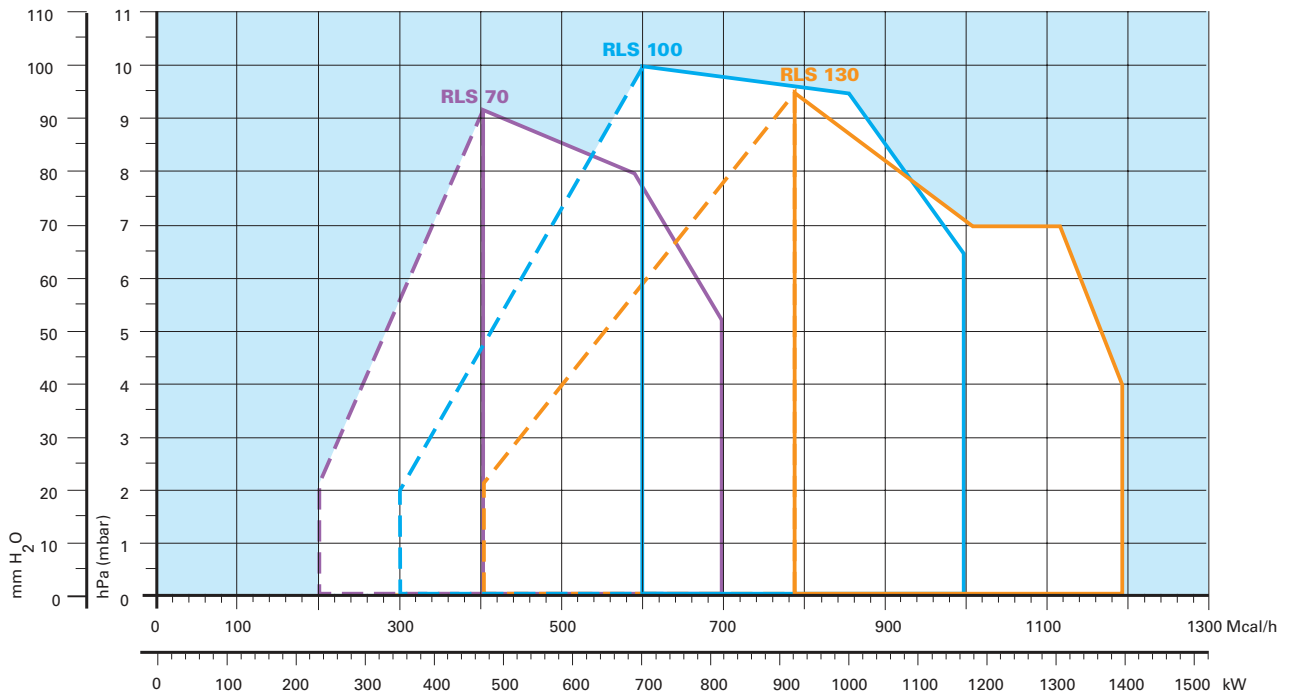
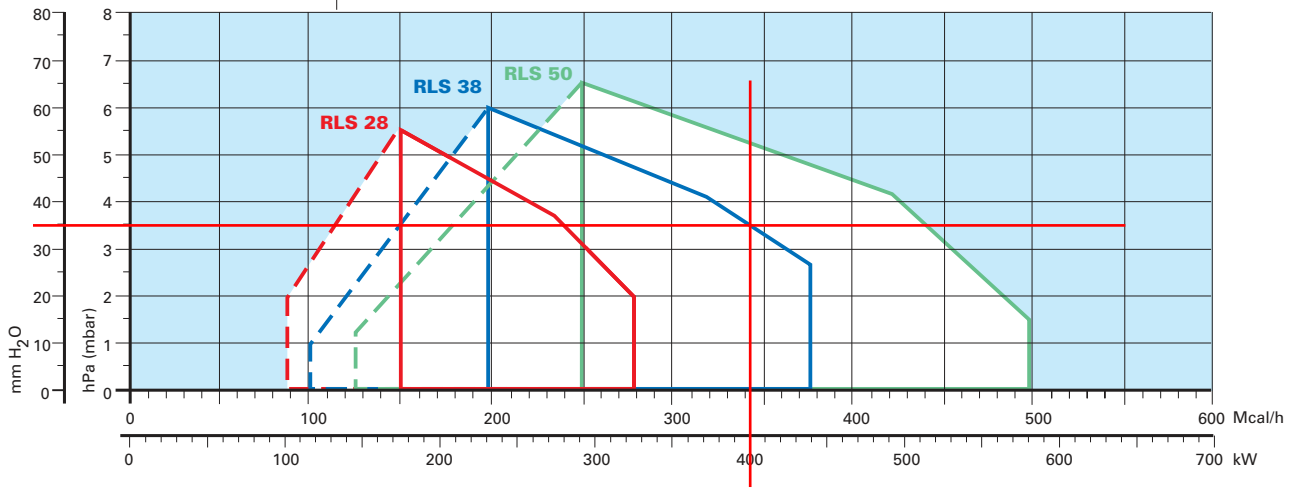

 Useful working field for choosing the burner

 Modulating range

Test conditions conforming to EN 267 - EN 676:

Temperature: 20°C
 Pressure: 1013.5 mbar
 Altitude: 100 m a.s.l.



FUEL SUPPLY

GASTRAIN

The gas trains are fitted with a regulating valve to adjust fuel delivery in relation to heat required. This valve is controlled by the two-stages device fitted on the burner.

Fuel can be supplied either from the right or left sides, on the basis of the application requirements. A maximum gas pressure switch stops the burner in case of excess of pressure in the supply line. The gas train can be selected to best fit system requirements depending on the fuel output and pressure in the supply line.

The gas trains can be "Multibloc" type (containing the main components in a single unit) or "Composed" type (assembly of the single components).

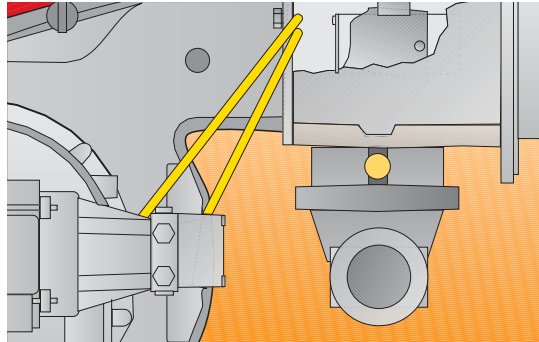

Example of gas inlet pipe burners for RLS 70-100-130

MULTIBLOC gas train without seal control

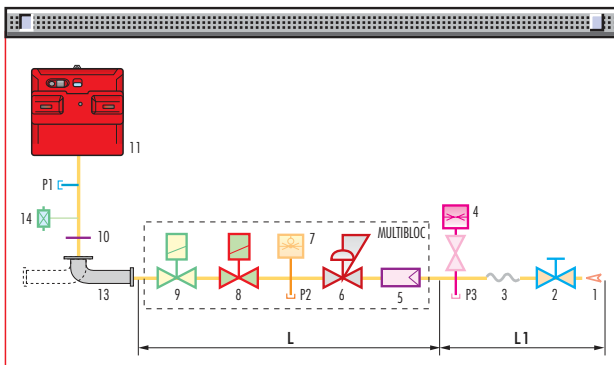

MULTIBLOC gas train with seal control

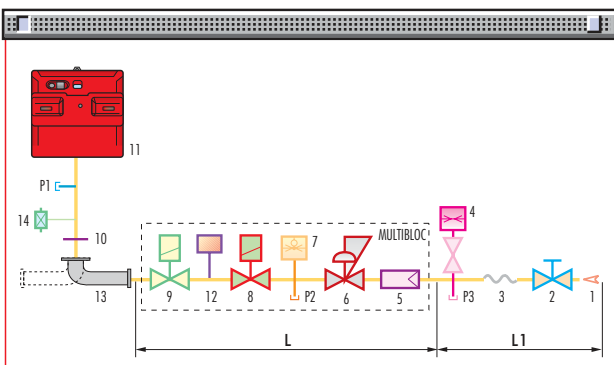

| | |
|----|---|
| 1 | Gas input pipework |
| 2 | Manual valve |
| 3 | Anti-vibration joint |
| 4 | Pressure gauge with pushbutton cock |
| 5 | Filter |
| 6 | Pressure regulator (vertical) |
| 7 | Minimum gas pressure switch |
| 8 | VS safety solenoid (vertical) |
| 9 | VR regulation solenoid (vertical). Three adjustments: - ignition delivery (rapid opening) - 1 st stage delivery (slow opening) - 2 nd stage delivery ((slow opening) |
| 10 | Gasket and flange supplied with the burner |
| 11 | Burner |
| 12 | Seal control mechanism for valves 8-9. According to standard EN 676, the seal control is compulsory for burners with maximum output above 1200 kW |
| 13 | Gas train-burner adapter. |
| 14 | Maximum gas pressure switch |
| P1 | Combustion head pressure |
| P2 | Pressure downstream from the regulator |
| P3 | Pressure upstream from the filter |
| L | Gas train supplied separately, with the code given in the table |
| L1 | Installer's responsibility |

COMPOSED gas train without seal control

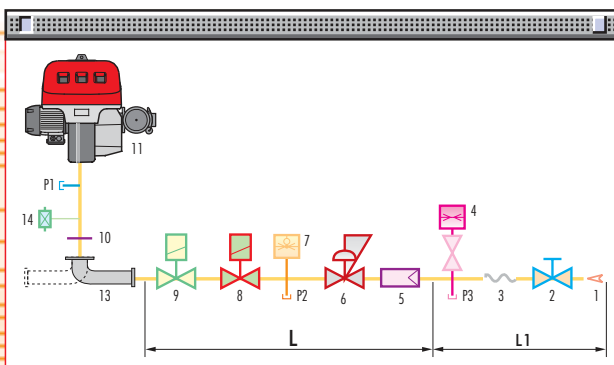

COMPOSED gas train with seal control

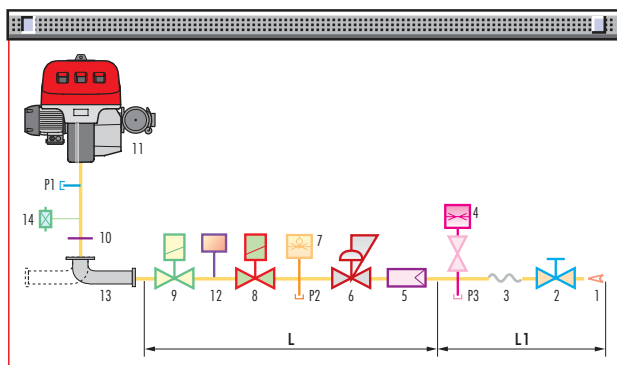

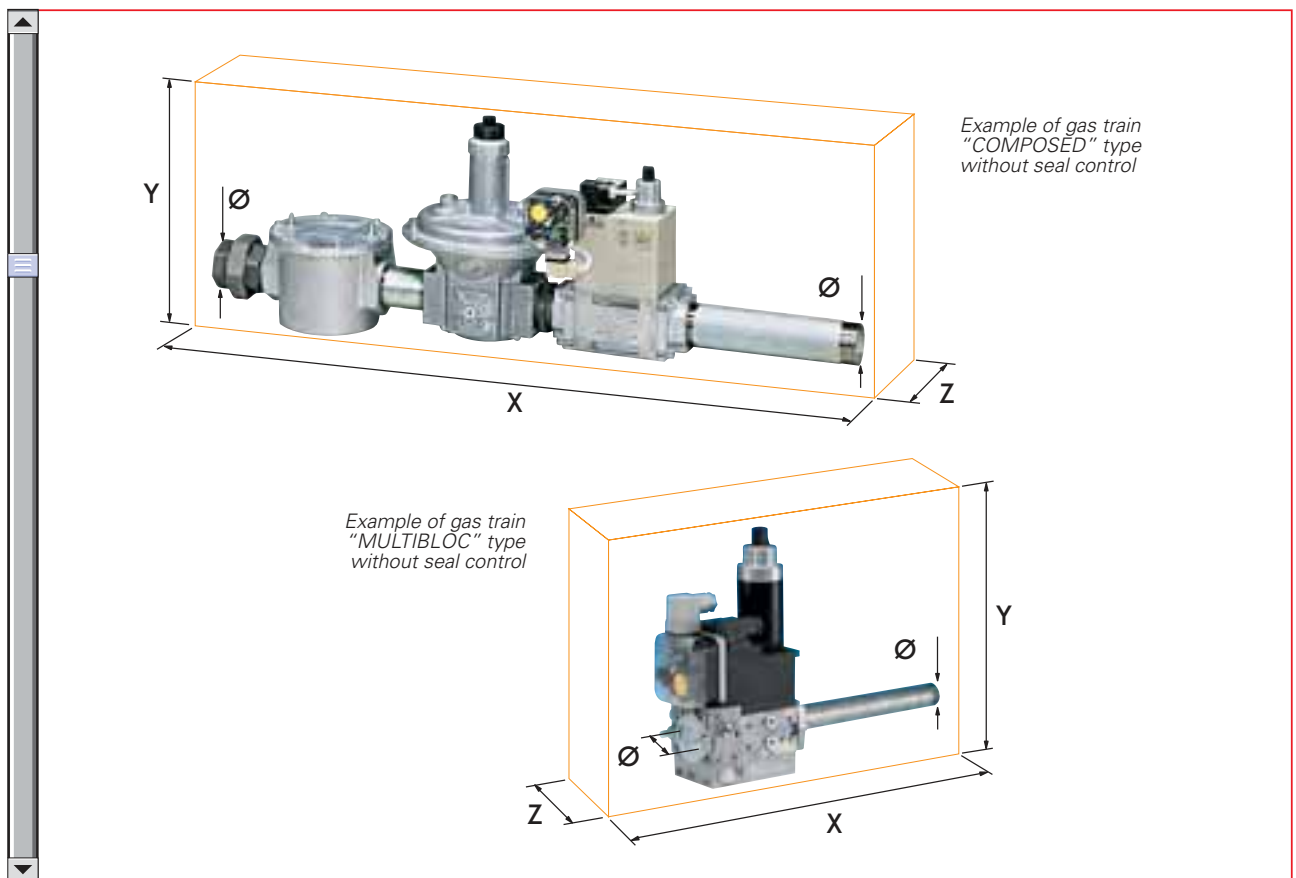

Gas trains are approved by standard EN 676 together with the burner.

The overall dimensions of the gas train depends on how they are constructed. The following table shows the maximum dimensions of the gas trains that can be fitted to RLS burners, intake and outlet diameters and seal control if fitted.

Please note that the seal control can be installed as an accessory, if not already installed on the gas train.

The maximum gas pressure of gas train "Multibloc" type is 300 mbar, and that one of gas train "Composed" type is 500 mbar.

| | Name | Code | Ø i | Ø o | X mm | Y mm | Z mm | Seal Control |
|---------------------------------|-----------------------|---------|--------|--------|------|------|--------------|--------------|
| MULTIBLOC GAS TRAINS | MBZRDLE 407 | 3970046 | 3/4" | 3/4" | 195 | 235 | 120 | - |
| | MBZRDLE 410 | 3970079 | 1" | 3/4" | 195 | 235 | 145 | - |
| | MBZRDLE 412 | 3970152 | 1" 1/4 | 1" 1/2 | 433 | 290 | 145 | - |
| | MBZRDLE 415 | 3970183 | 1" 1/2 | 1 21/2 | 523 | 346 | 100 | - |
| | MBZRDLE 420 | 3970184 | 2" | 2" | 523 | 400 | 100 | - |
| | MBZRDLE 420 CT | 3970185 | 2" | 2" | 523 | 400 | 227 | Incorporated |
| COMPOSED GAS TRAINS | CB 40/2 | 3970153 | 1" 1/2 | 1" 1/2 | 1013 | 346 | 195 | - |
| | CB 50/2 | 3970154 | 2" | 2" | 1150 | 354 | 250 | - |
| | CB 50/2 CT | 3970166 | 2" | 2" | 1150 | 354 | 320 | Incorporated |
| | CBF 65/2 | 3970155 | DN 65 | DN 65 | 1166 | 475 | 285 | - |
| | CBF 65/2 CT | 3970167 | DN 65 | DN 65 | 1166 | 475 | 285 | Incorporated |
| | CBF 80/2 | 3970156 | DN 80 | DN 80 | 1246 | 425 | 285 | - |
| CBF 80/2 CT | 3970168 | DN 80 | DN 80 | 1246 | 425 | 285 | incorporated | |



► PRESSURE DROP DIAGRAMS

The diagrams indicate the minimum pressure drop of the burners with the various gas trains that can be matched with them; at the value of these pressure drop add the combustion chamber pressure.

The value thus calculated represents the minimum required input pressure to the gas train.

NATURAL GAS

LPG

RLS 28

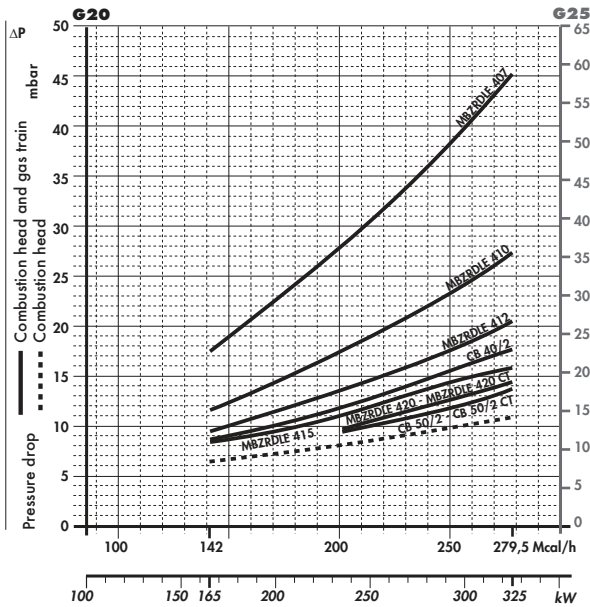

| Gas train | Code | Adapter | Seal Control |
|------------|---------|---------|--------------|
| MBZRDL 407 | 3970046 | 3000824 | Accessory |
| MBZRDL 410 | 3970079 | 3000824 | Accessory |
| MBZRDL 412 | 3970152 | - | Accessory |
| MBZRDL 415 | 3970183 | - | Accessory |
| CB 40/2 | 3970153 | - | Accessory |

RLS 28

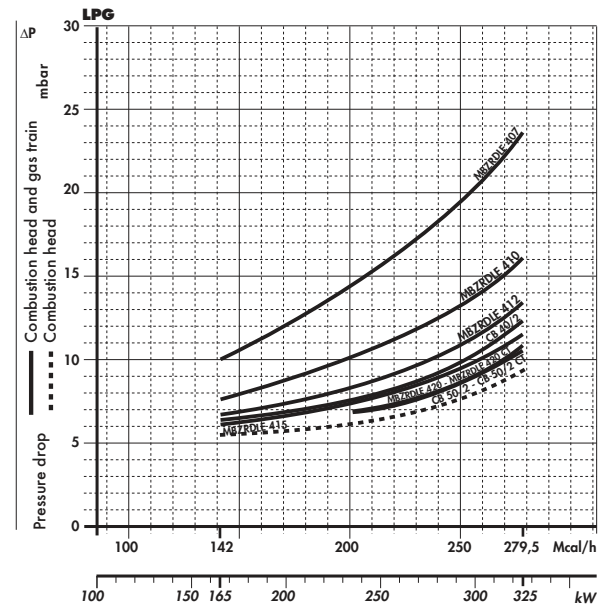

| Gas train | Code | Adapter | Seal Control |
|---------------|---------|---------|--------------|
| MBZRDL 420 | 3970184 | 3000822 | Accessory |
| MBZRDL 420 CT | 3970185 | 3000822 | Incorporated |
| CB 50/2 | 3970154 | 3000822 | Accessory |
| CB 50/2 CT | 3970166 | 3000822 | Incorporated |

RLS 38

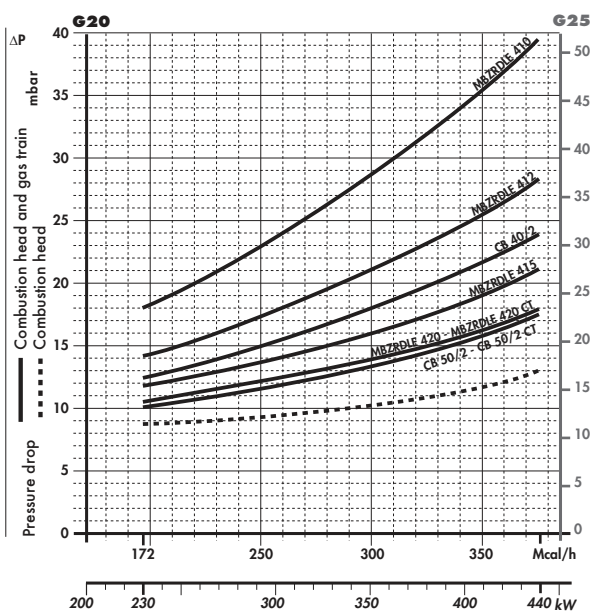

| Gas train | Code | Adapter | Seal Control |
|------------|---------|---------|--------------|
| MBZRDL 410 | 3970079 | 3000824 | Accessory |
| MBZRDL 412 | 3970152 | - | Accessory |
| MBZRDL 415 | 3970183 | - | Accessory |
| CB 40/2 | 3970153 | - | Accessory |

RLS 38

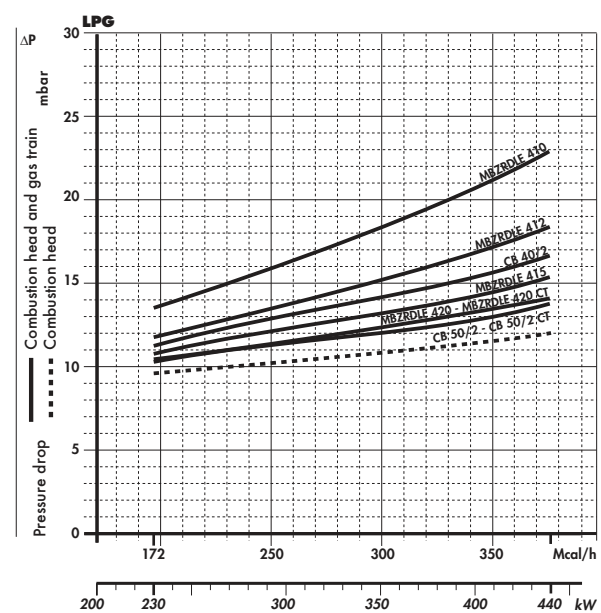

| Gas train | Code | Adapter | Seal Control |
|---------------|---------|---------|--------------|
| MBZRDL 420 | 3970184 | 3000822 | Accessory |
| MBZRDL 420 CT | 3970185 | 3000822 | Incorporated |
| CB 50/2 | 3970154 | 3000822 | Accessory |
| CB 50/2 CT | 3970166 | 3000822 | Incorporated |



NATURAL GAS

LPG

RLS 50

RLS 50

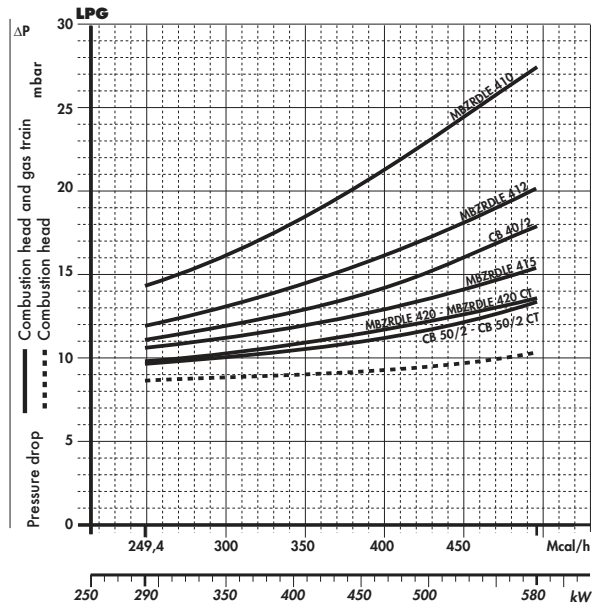
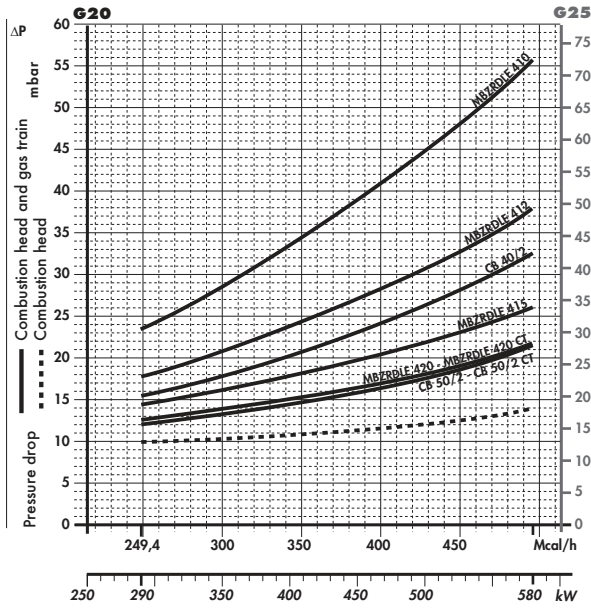

| Gas train | Code | Adapter | Seal Control |
|-------------|---------|---------|--------------|
| MBZRDLE 410 | 3970079 | 3000824 | Accessory |
| MBZRDLE 412 | 3970152 | - | Accessory |
| MBZRDLE 415 | 3970183 | - | Accessory |
| CB 40/2 | 3970153 | - | Accessory |

| Gas train | Code | Adapter | Seal Control |
|----------------|---------|---------|--------------|
| MBZRDLE 420 | 3970184 | 3000822 | Accessory |
| MBZRDLE 420 CT | 3970185 | 3000822 | Incorporated |
| CB 50/2 | 3970154 | 3000822 | Accessory |
| CB 50/2 CT | 3970166 | 3000822 | Incorporated |

RLS 70

RLS 70

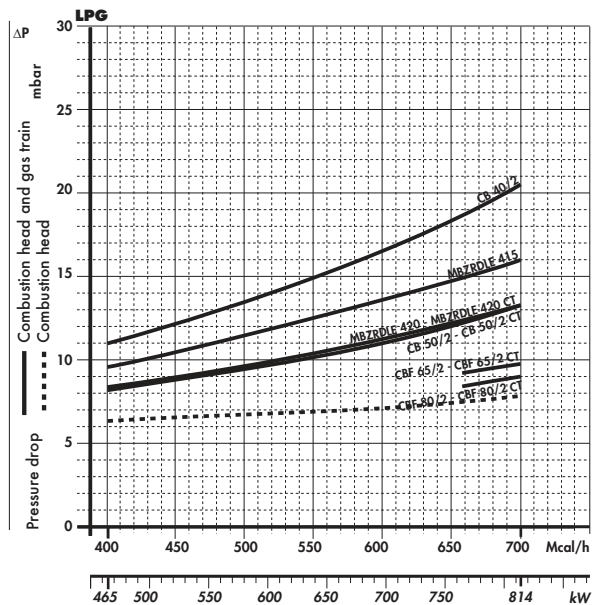
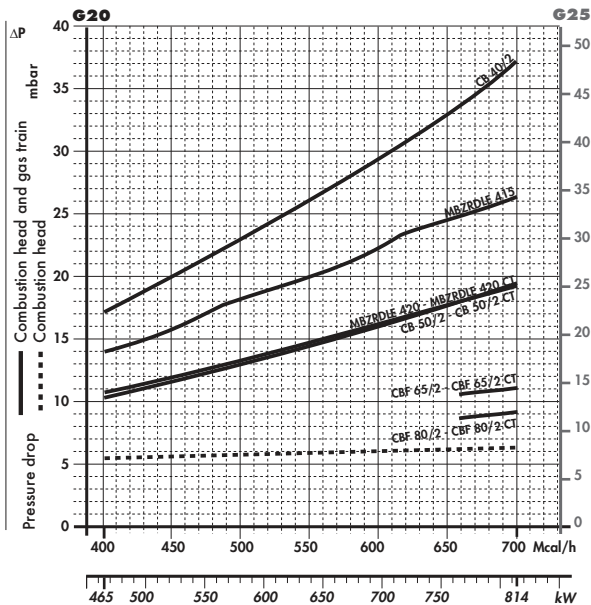

| Gas train | Code | Adapter | Seal Control |
|----------------|---------|---------|--------------|
| MBZRDLE 415 | 3970183 | 3000843 | Accessory |
| CB 40/2 | 3970153 | 3000843 | Accessory |
| MBZRDLE 420 | 3970184 | - | Accessory |
| MBZRDLE 420 CT | 3970185 | - | Incorporated |
| CB 50/2 | 3970154 | - | Accessory |

| Gas train | Code | Adapter | Seal Control |
|-------------|---------|---------|--------------|
| CB 50/2 CT | 3970166 | - | Incorporated |
| CBF 65/2 | 3970155 | 3000825 | Accessory |
| CBF 65/2 CT | 3970167 | 3000825 | Incorporated |
| CBF 80/2 | 3970156 | 3000826 | Accessory |
| CBF 80/2 CT | 3970168 | 3000826 | Incorporated |



NATURAL GAS

LPG

RLS 100

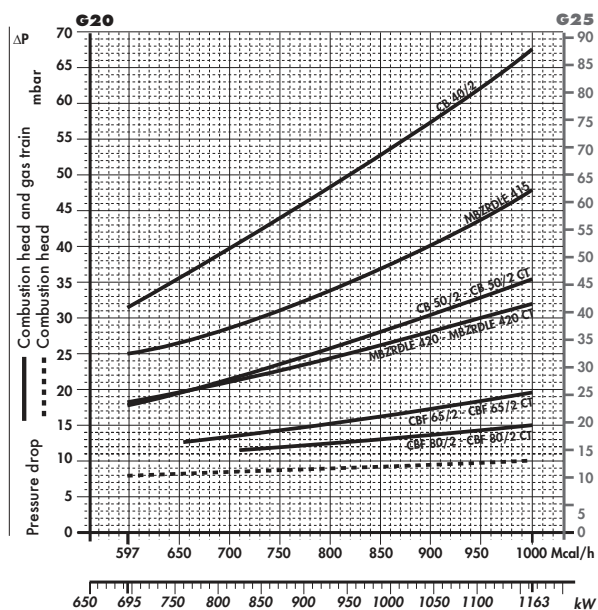

| Gas train | Code | Adapter | Seal Control |
|----------------|---------|---------|--------------|
| MBZRDLE 415 | 3970183 | 3000843 | Accessory |
| CB 40/2 | 3970153 | 3000843 | Accessory |
| MBZRDLE 420 | 3970184 | - | Accessory |
| MBZRDLE 420 CT | 3970185 | - | Incorporated |
| CB 50/2 | 3970154 | - | Accessory |

RLS 100

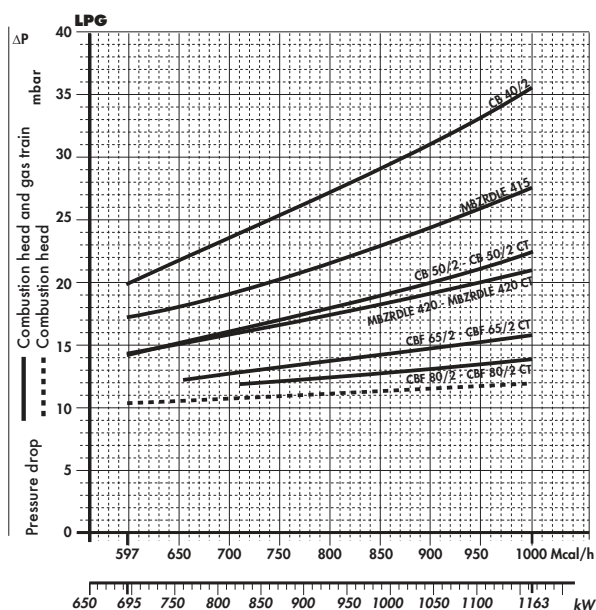

| Gas train | Code | Adapter | Seal Control |
|-------------|---------|---------|--------------|
| CB 50/2 CT | 3970166 | - | Incorporated |
| CBF 65/2 | 3970155 | 3000825 | Accessory |
| CBF 65/2 CT | 3970167 | 3000825 | Incorporated |
| CBF 80/2 | 3970156 | 3000826 | Accessory |
| CBF 80/2 CT | 3970168 | 3000826 | Incorporated |

RLS 130

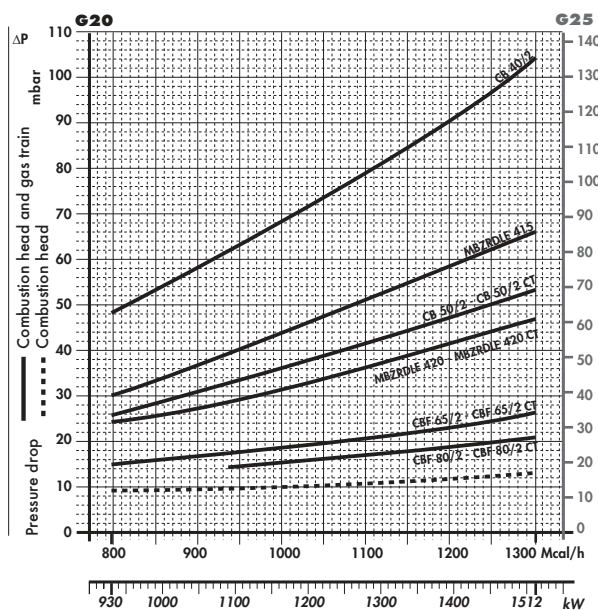

| Gas train | Code | Adapter | Seal Control |
|----------------|---------|---------|--------------|
| MBZRDLE 415 | 3970183 | 3000843 | Accessory |
| CB 40/2 | 3970153 | 3000843 | Accessory |
| MBZRDLE 420 | 3970184 | - | Accessory |
| MBZRDLE 420 CT | 3970185 | - | Incorporated |
| CB 50/2 | 3970154 | - | Accessory |

RLS 130

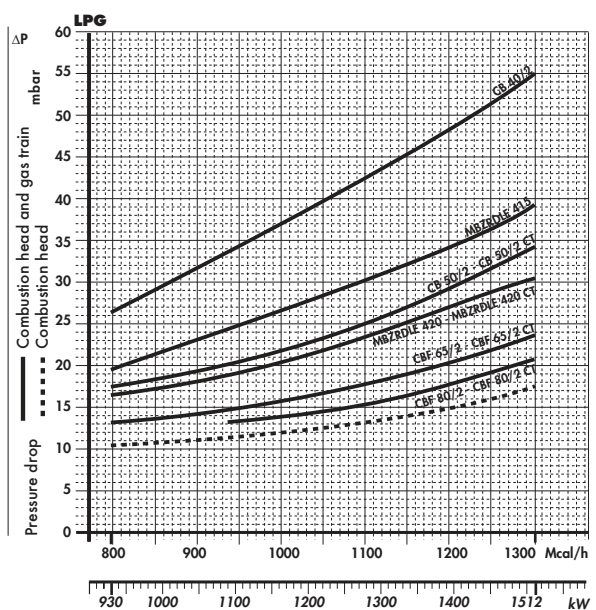

| Gas train | Code | Adapter | Seal Control |
|-------------|---------|---------|--------------|
| CB 50/2 CT | 3970166 | - | Incorporated |
| CBF 65/2 | 3970155 | 3000825 | Accessory |
| CBF 65/2 CT | 3970167 | 3000825 | Incorporated |
| CBF 80/2 | 3970156 | 3000826 | Accessory |
| CBF 80/2 CT | 3970168 | 3000826 | Incorporated |

note Please contact the Riello Burner Technical Office for different pressure levels from those above indicated.



▶ SELECTING THE FUEL SUPPLY LINES

The following diagram enables pressure drop in a pre-existing gas line to be calculated and to select the correct gas train.

The diagram can also be used to select a new gas line when fuel output and pipe length are known. The pipe diameter is selected on the basis of the desired pressure drop. The diagram uses methane gas as reference; if another gas is used, conversion coefficient and a simple formula (on the diagram) transform the gas output to a methane equivalent (refer to figure A). Please note that the gas train dimensions must take into account the back pressure of the combustion chamber during operations.

Control of the pressure drop in an existing gas line or selecting a new gas supply line.

The methane output equivalent is determined by the formula fig. A on the diagram and the conversion coefficient.

Once the equivalent output has been determined on the delivery scale (\dot{V}), shown at the top of the diagram, move vertically downwards until you cross the line that represents the pipe diameter; at this point, move horizontally to the left until you meet the line that represents the pipe length.

Once this point is established you can verify, by moving vertically downwards, the pipe pressure drop on the bottom scale below (mbar).

By subtracting this value from the pressure measured on the gas meter, the correct pressure value will be found for the choice of gas train.

Example:

- gas used G25
- gas output 9.51 mc/h
- pressure at the gas meter 20 mbar
- gas line length 15 m
- conversion coefficient 0.62 (see figure A)

- equivalent methane output $\dot{V} = \left[\frac{9.51}{0.62} \right] = 15.34 \text{ mc/h}$

- once the value of 15.34 has been identified on the output scale (\dot{V}), moving vertically downwards you cross the line that represents 1" 1/4 (the chosen diameter for the piping);

- from this point, move horizontally to the left until you meet the line that represents the length of 15 m of the piping;

- move vertically downwards to determine a value of 1.4 mbar in the pressure drop bottom scale;

- subtract the determined pressure drop from the meter pressure, the correct pressure level will be found for the choice of gas train;

- correct pressure = (20-1.4) = 18.6 mbar

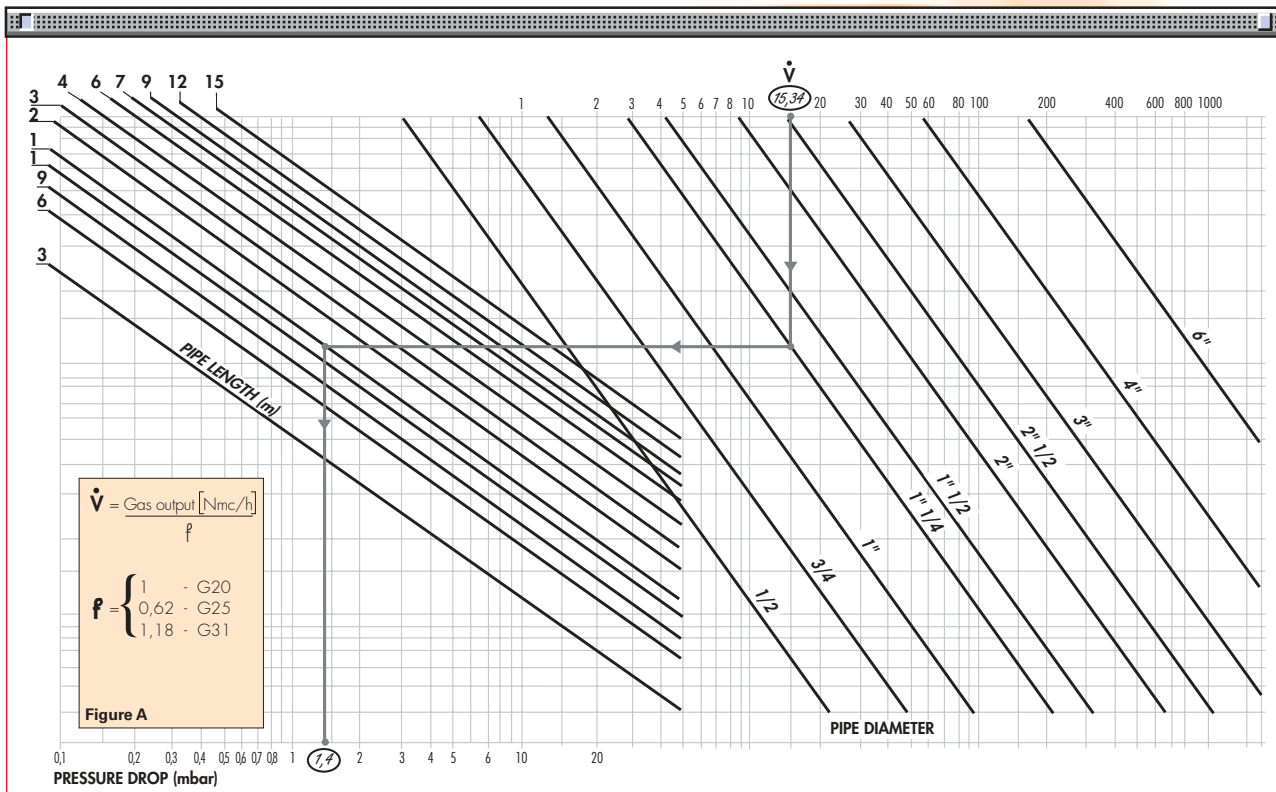



► HYDRAULIC CIRCUIT

The burners are fitted with three valves (a safety valve and two oil delivery valves) along the oil line from the pump to the nozzle.

A thermostatic control device, on the basis of required output, regulates oil delivery valves opening, allowing light oil passage through the valves and to the nozzle. Delivery valves open contemporary to the air damper opening, controlled by a servomotor.

The pumping group is fitted with a pump, an oil filter and a regulating valve: through this it is possible to manually adjust atomised pressure, which is factory set at 12 bar.

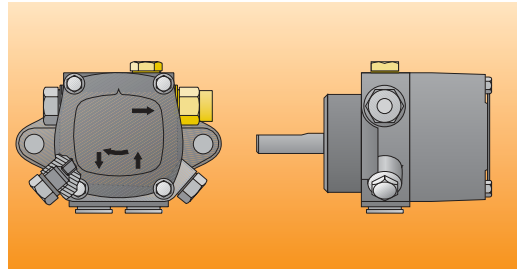

Example of light oil pump of RLS 70-100-130 burners

RLS 28-38-50

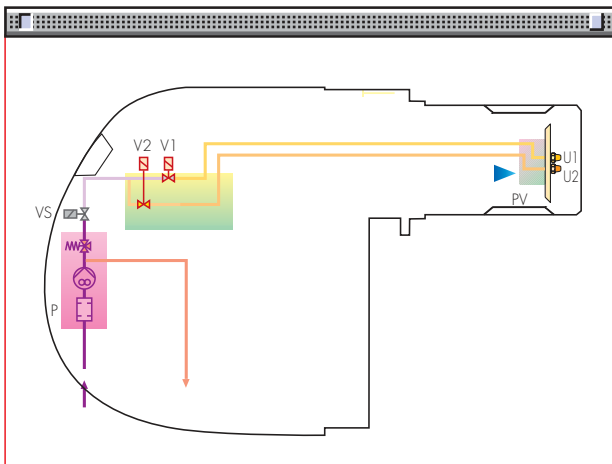

RLS 70-100-130

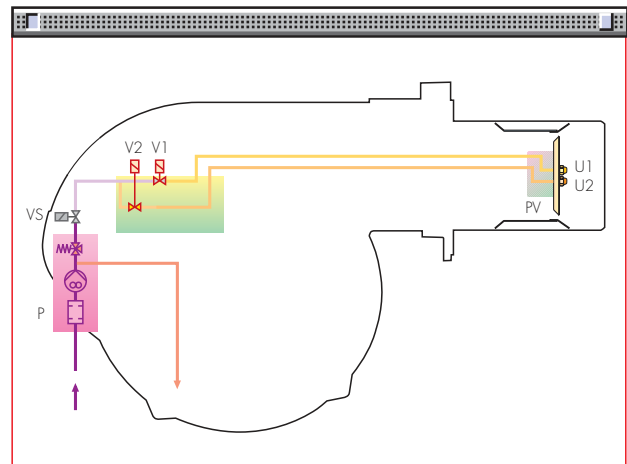

| | |
|----|---|
| P | Pump with filter and pressure regulator on the output circuit |
| VS | Safety valve on the output circuit |
| V1 | 1st stage valve |
| V2 | 2nd stage valve |
| PV | Nozzle holder |
| U1 | 1st stage nozzle |
| U2 | 2nd stage nozzle |

DIMENSIONING OF THE FUEL SUPPLY LINES

The fuel feed must be completed with the safety devices required by the local norms.

The table shows the choice of piping diameter for the various burners, depending on the difference in height between the burner and the tank and their distance.

| MAXIMUM EQUIVALENT LENGTH FOR THE PIPING L[m] | | | | | | |
|---|--------------------|----------|----------|----------------------|----------|----------|
| Model | ▼ RLS 28 - 38 - 50 | | | ▼ RLS 70 - 100 - 130 | | |
| Piping diameter | 8mm | 10mm | 12mm | 12mm | 14mm | 16mm |
| +H, -H (m) | Lmax (m) | Lmax (m) | Lmax (m) | Lmax (m) | Lmax (m) | Lmax (m) |
| +4,0 | 35 | 90 | 152 | 71 | 138 | 150 |
| +3,0 | 30 | 80 | 152 | 62 | 122 | 150 |
| +2,0 | 26 | 69 | 152 | 53 | 106 | 150 |
| +1,5 | 22 | 54 | 141 | 49 | 98 | 150 |
| +1,0 | 21 | 59 | 130 | 44 | 90 | 150 |
| +0,5 | 19 | 53 | 119 | 40 | 82 | 150 |
| 0 | 17 | 48 | 108 | 36 | 74 | 137 |
| -0,5 | 15 | 43 | 97 | 32 | 66 | 123 |
| -1,0 | 13 | 37 | 83 | 28 | 56 | 109 |
| -1,5 | 11 | 32 | 74 | 24 | 49 | 95 |
| -2,0 | 9 | 27 | 64 | 19 | 42 | 81 |
| -3,0 | 4 | 16 | 42 | 10 | 26 | 53 |
| -4,0 | - | 6 | 20 | - | 10 | 25 |

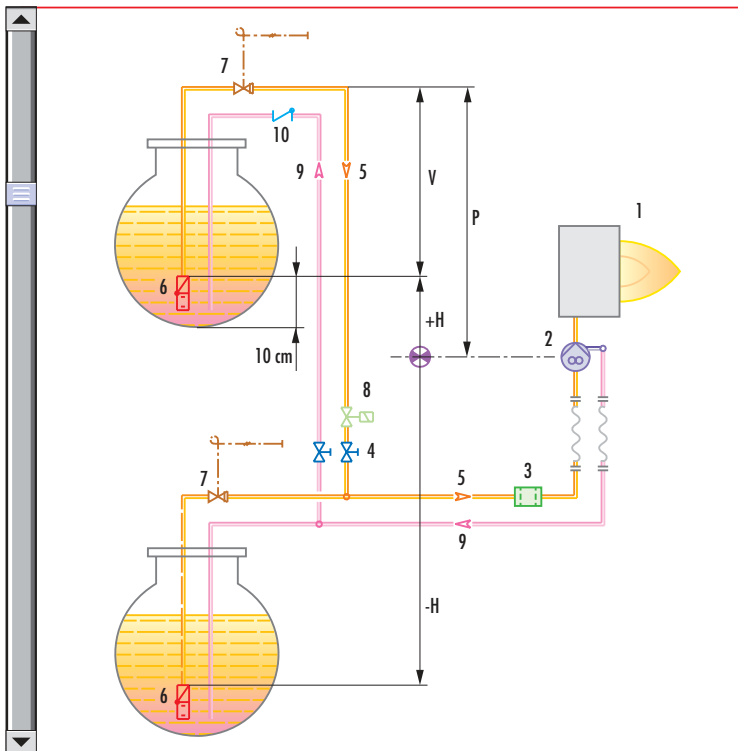

| | |
|----|--|
| H | Difference in height pump-foot valve |
| ∅ | Internal pipe diameter |
| P | Height " 10 m |
| V | Height " 4 m |
| 1 | Burner |
| 2 | Burner pump |
| 3 | Filter |
| 4 | Manual shut off valve |
| 5 | Suction pipework |
| 6 | Bottom valve |
| 7 | Remote controlled rapid manual shutoff valve (compulsory in Italy) |
| 8 | Type approved shut off solenoid (compulsory in Italy) |
| 9 | Return pipework |
| 10 | Check valve |

note With ring distribution oil systems, the feasible drawings and dimensioning are the responsibility of specialised engineering studios, who must check compatibility with the requirements and features of each single installation.



VENTILATION

The ventilation circuit guarantees low noise levels with high performances in pressure and air delivery, in spite of compact dimensions.

The use of reverse curve blades and sound proofing material keeps noise level very low.

The result is a powerful yet quiet burner with increased combustion performance.

A servomotor allows to have a right air flow in any operation state and the closure of the air damper when burner is in stand-by.

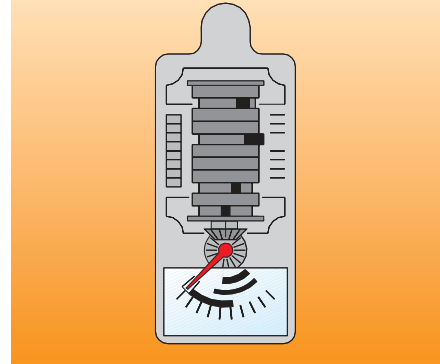

Example of the servomotor for air regulation on RLS 70-100-130 burners.

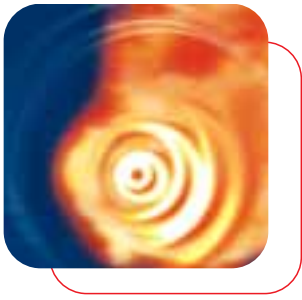

COMBUSTION HEAD

Different lengths of the combustion head can be supplied (with application of a specific "extended head kit") for the RLS series of burners.

The selection depends on the thickness of the front panel and on the type of boiler.

Depending on the type of generator, check that the penetration of the head into the combustion chamber is correct. The internal position of the combustion head can easily be adjusted to the maximum defined output by regulating a screw fixed to the flange.



Example of RLS 130 burners combustion head.

Dimensions of the flame

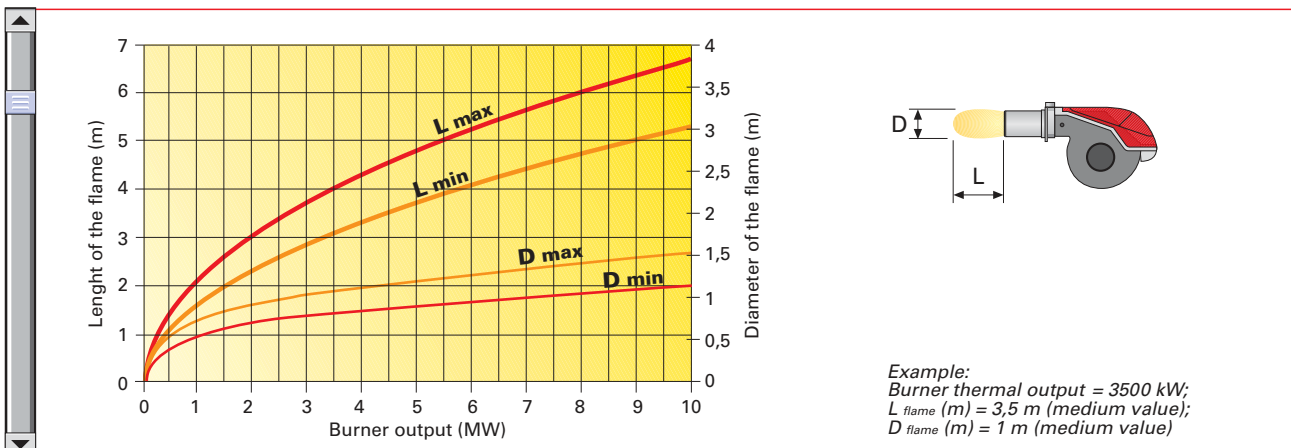

OPERATION



BURNER OPERATION MODE

With two-stage operation, the RLS series of burners can follow the temperature load requested by the system. A modulation ratio of 2:1 is reached thanks to the nozzles when burner is supplied with light oil and to the two-stage gas train when burner is supplied from gas; the air is adapted to the servomotor rotations.

On "two-stage" operation, the burner gradually adjusts output to the requested level, by varying between two pre-set levels (see picture A).

Two stage operation

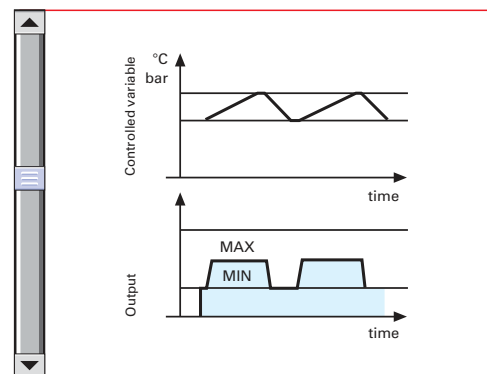

Picture A

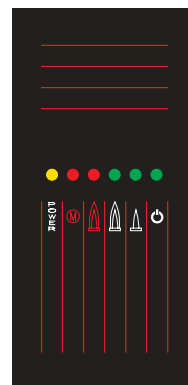

- = Power on
- = Fan motor blocked (red)
- = Burner lock-out (red)
- = 2nd stage operation
- = 1st stage operation
- = Burner operating

Picture B: Layout of "Led Panel"

The RLS burners are equipped with an exclusive electronic device "Led panel" that provides the six data items signalled by the leds lighting up of picture B.

START UP CYCLE

RLS 28 - 38 - 50 - 70 - 100 - 130

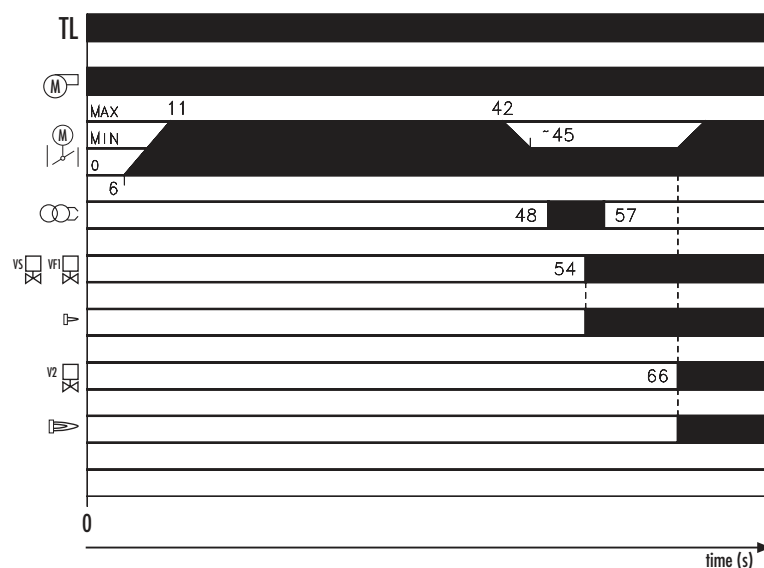

- 0" Thermostat closes. The motor starts running.
- 6"-11" The servomotor opens the air damper.
- 11"-42" Pre-purge with air damper open.
- 42"-45" The servomotor takes the air damper to the firing position.
- 48" Pre-ignition
- 54" Solenoid security valve VS and V1 1st stage valve open; 1st stage flame
- 57" After 3" firing the ignition transformer switches off (if flame is detected, otherwise there is a lock-out)
- 66" If heat request is not yet satisfied, 2nd stage solenoid valve V2 opens and at the same time servomotor open completely the air damper. The starting cycle comes to an end. 2nd stage flame.



WIRING DIAGRAMS

Electrical connections must be made by qualified and skilled personnel, according to the local norms.



Example of the terminal board for electrical connections for RLS 28-38 burner models

TWO STAGE OPERATION

RLS 28-38
Without seal control

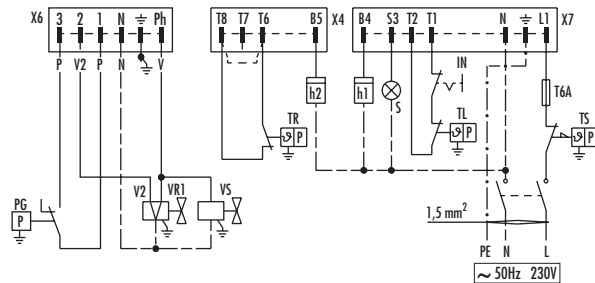

- h1** - 1st stage hourcounter
- h2** - 2nd stage hourcounter
- IN** - Burner manual stop switch
- XP** - Plug for seal control device
- X4** - 4 pole plug
- X6** - 6 pole plug
- X7** - 7 pole plug
- PG** - Min gas pressure switch
- S** - Remote lock-out signal
- S1** - Remote lock-out signal of seal control device
- TR** - High-low mode load remote control system
- TL** - Load limit remote control system
- TS** - Safety load control system
- VR1** - Regulating valve 1st stage
- VR2** - Regulating valve 2nd stage
- VS** - Safety valve

RLS 28-38
With seal control

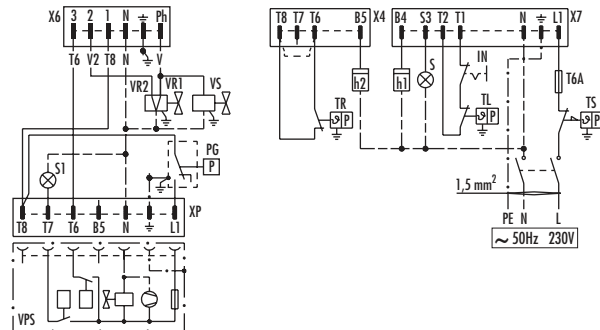

- h1** - 1st stage hourcounter
- h2** - 2nd stage hourcounter
- IN** - Burner manual stop switch
- XP** - Plug for seal control device
- X4** - 4 pole plug
- X6** - 6 pole plug
- X7** - 7 pole plug
- PG** - Min gas pressure switch
- S** - Remote lock-out signal
- S1** - Remote lock-out signal of seal control device
- TR** - High-low mode load remote control system
- TL** - Load limit remote control system
- TS** - Safety load control system
- VR1** - Regulating valve 1st stage
- VR2** - Regulating valve 2nd stage
- VS** - Safety valve



RLS 50 Without seal control

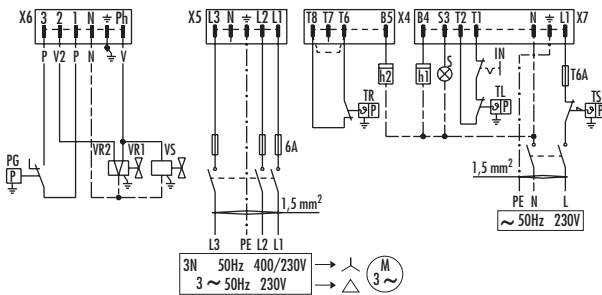

- h1** - 1st stage hourcounter
- h2** - 2nd stage hourcounter
- IN** - Burner manual stop switch
- XP** - Plug for seal control device
- X4** - 4 pole plug
- X5** - 5 pole plug
- X6** - 6 pole plug
- X7** - 7 pole plug
- PG** - Min gas pressure switch
- S** - Remote lock-out signal
- S1** - Remote lock-out signal of seal control device
- TR** - High-low mode load remote control system
- TL** - Load limit remote control system
- TS** - Safety load control system
- VR1** - Regulating valve 1st stage
- VR2** - Regulating valve 2nd stage
- VS** - Safety valve

RLS 50 With seal control

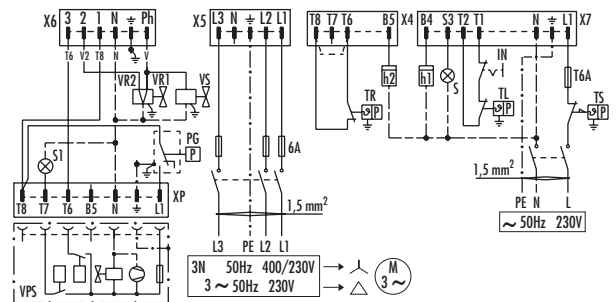

- h1** - 1st stage hourcounter
- h2** - 2nd stage hourcounter
- IN** - Burner manual stop switch
- XP** - Plug for seal control device
- X4** - 4 pole plug
- X5** - 5 pole plug
- X6** - 6 pole plug
- X7** - 7 pole plug
- PG** - Min gas pressure switch
- S** - Remote lock-out signal
- S1** - Remote lock-out signal of seal control device
- TR** - High-low mode load remote control system
- TL** - Load limit remote control system
- TS** - Safety load control system
- VR1** - Regulating valve 1st stage
- VR2** - Regulating valve 2nd stage
- VS** - Safety valve

RLS 70-100-130 Without seal control

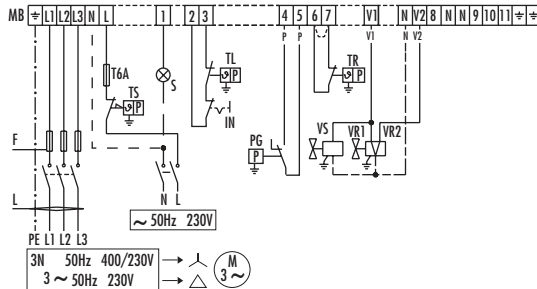

- IN** - Burner manual stop switch
- XP** - Plug for seal control device
- MB** - Burner terminal board
- PG** - Min gas pressure switch
- S** - Remote lock-out signal
- S1** - Remote lock-out signal of seal control device
- TR** - High-low mode load remote control system
- TL** - Load limit remote control system
- TS** - Safety load control system
- VR1** - Regulating valve 1st stage
- VR2** - Regulating valve 2nd stage
- VS** - Safety valve

RLS 70-100-130 With seal control

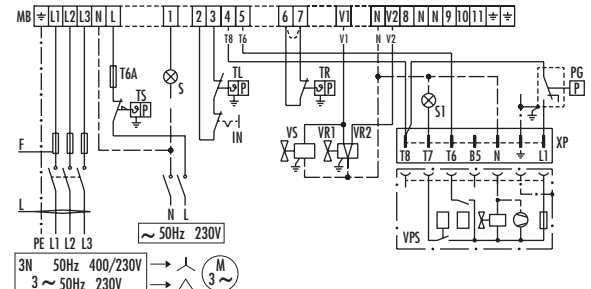

- IN** - Burner manual stop switch
- XP** - Plug for seal control device
- MB** - Burner terminal board
- PG** - Min gas pressure switch
- S** - Remote lock-out signal
- S1** - Remote lock-out signal of seal control device
- TR** - High-low mode load remote control system
- TL** - Load limit remote control system
- TS** - Safety load control system
- VR1** - Regulating valve 1st stage
- VR2** - Regulating valve 2nd stage
- VS** - Safety valve

The following table shows the supply lead sections and the type of fuse to be used.

| Model | ▼ RLS 28 | ▼ RLS 38 | ▼ RLS 50 | | ▼ RLS 70 | | ▼ RLS 100 | | ▼ RLS 130 | |
|-------------------|----------|----------|----------|------|----------|------|-----------|------|-----------|------|
| | 230V | 230V | 230V | 400V | 230V | 400V | 230V | 400V | 230V | 400V |
| F A | T6 | T6 | T10 | T6 | T10 | T6 | T10 | T6 | T10 | T6 |
| L mm ² | 1,5 | 1,5 | 1,5 | 1,5 | 1,5 | 1,5 | 1,5 | 1,5 | 1,5 | 1,5 |

Table A



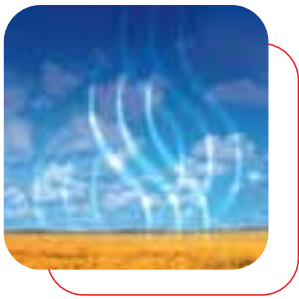

EMISSIONS



NO_x EMISSIONS

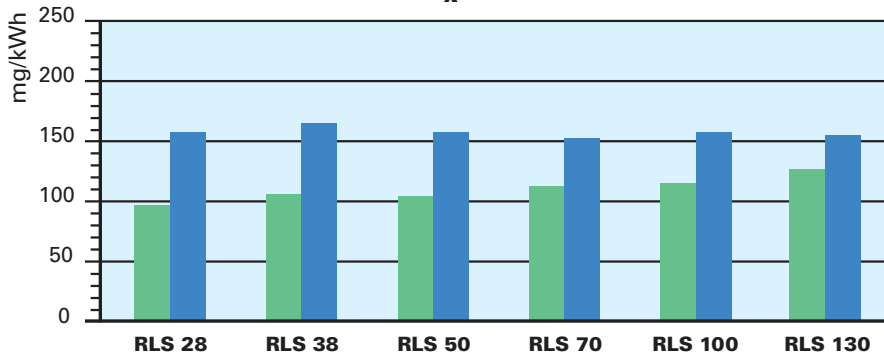

Gas working
Light oil working

CO EMISSIONS

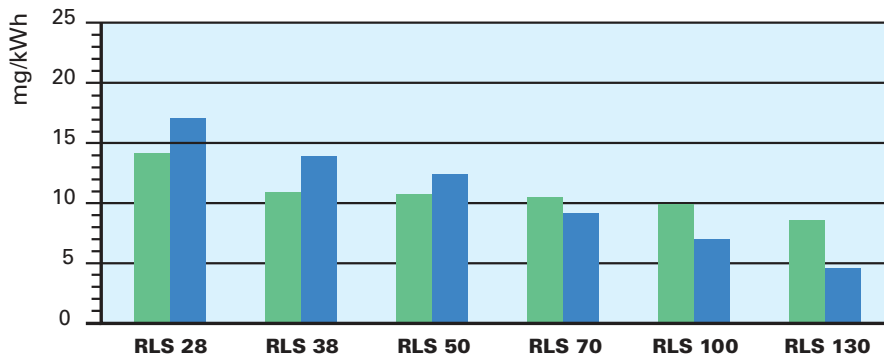

The emission data has been measured in the various models at maximum output, according to EN 676 and EN 267 standard.

NOISE EMISSIONS

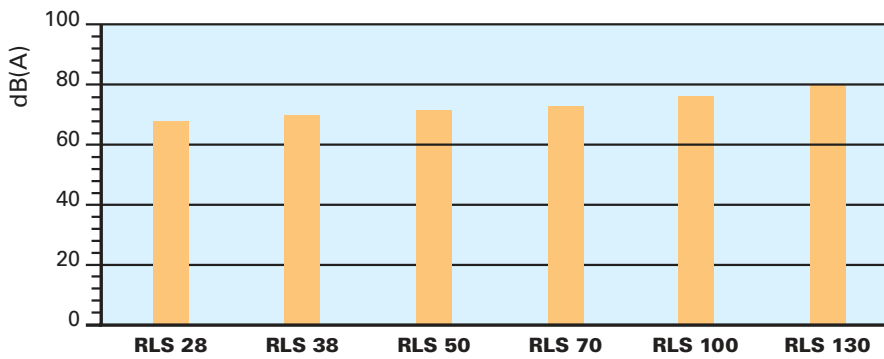

OVERALL DIMENSIONS (mm)



BURNERS

RLS 28 - 38 - 50

RLS 70 - 100 - 130

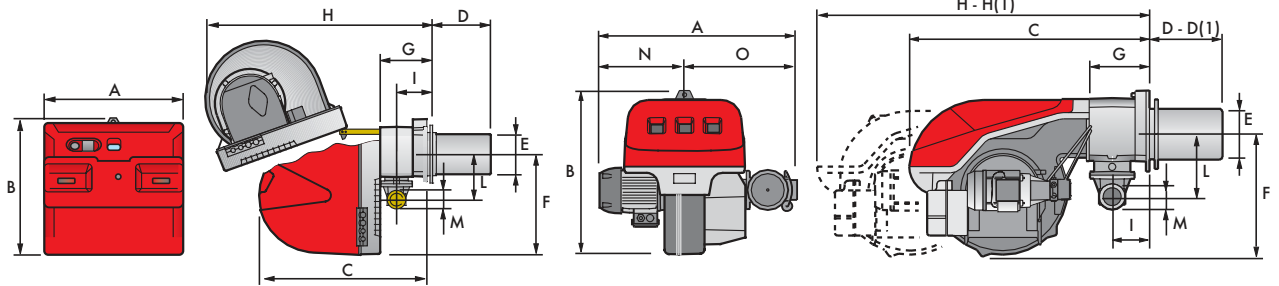

| Model | A | B | C | D | D(1) | E | F | G | H | H(1) | I | L | M | N | O |
|-----------|-----|-----|-----|-----|------|-----|-----|-----|------|------|-----|-----|-------|-----|-----|
| ▶ RLS 28 | 476 | 474 | 580 | 191 | 326 | 140 | 352 | 164 | 810 | 810 | 108 | 168 | 1"1/2 | - | - |
| ▶ RLS 38 | 476 | 474 | 580 | 201 | 336 | 152 | 352 | 164 | 810 | 810 | 108 | 168 | 1"1/2 | - | - |
| ▶ RLS 50 | 476 | 474 | 580 | 216 | 351 | 152 | 352 | 164 | 810 | 810 | 108 | 168 | 1"1/2 | - | - |
| ▶ RLS 70 | 691 | 555 | 840 | 250 | 385 | 179 | 430 | 214 | 1161 | 1361 | 134 | 221 | 2" | 296 | 395 |
| ▶ RLS 100 | 707 | 555 | 840 | 250 | 385 | 189 | 430 | 214 | 1161 | 1361 | 134 | 221 | 2" | 312 | 395 |
| ▶ RLS 130 | 733 | 555 | 840 | 250 | 385 | 189 | 430 | 214 | 1161 | 1361 | 134 | 221 | 2" | 338 | 395 |

(1) Dimension with "extended head".

BURNER - BOILER MOUNTING FLANGE

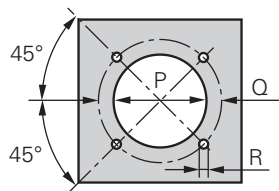

| Model | P | Q | R |
|-----------|-----|---------|-----|
| ▶ RLS 28 | 160 | 224 | M8 |
| ▶ RLS 38 | 160 | 224 | M8 |
| ▶ RLS 50 | 160 | 224 | M8 |
| ▶ RLS 70 | 185 | 275-325 | M12 |
| ▶ RLS 100 | 195 | 275-325 | M12 |
| ▶ RLS 130 | 195 | 275-325 | M12 |

PACKAGING

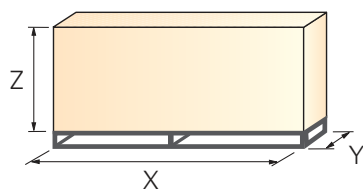

| Model | X | Y | Z | kg |
|-----------|------|------|-----|----|
| ▶ RLS 28 | 1190 | 492 | 510 | 43 |
| ▶ RLS 38 | 1190 | 492 | 510 | 45 |
| ▶ RLS 50 | 1190 | 492 | 510 | 46 |
| ▶ RLS 70 | 1405 | 1000 | 660 | 70 |
| ▶ RLS 100 | 1405 | 1000 | 660 | 73 |
| ▶ RLS 130 | 1405 | 1000 | 660 | 76 |





INSTALLATION DESCRIPTION

Installation, start up and maintenance must be carried out by qualified and skilled personnel. All operations must be performed in accordance with the technical handbook supplied with the burner.

▶ BURNER SETTING

- ▶ All the burners have slide bars, for easier installation and maintenance.
- ▶ After drilling the boilerplate, using the supplied gasket as a template, dismantle the blast tube from the burner and fix it to the boiler.
- ▶ Adjust the combustion head.
- ▶ Fit the gas train choosing this on the basis of the maximum boiler output and following the diagrams included in the burner instruction handbook
- ▶ Refit the burner casing to the slide bars.
- ▶ Install the nozzle choosing this on the basis of the maximum boiler output and following the diagrams included in the burner instruction handbook.
- ▶ Check the position of the electrodes.
- ▶ Close the burner, sliding it up to the flange, keeping it slightly raised to avoid the flame stability disk rubbing against the blast tube.

▶ ELECTRICAL AND HYDRAULIC CONNECTIONS AND START UP

- ▶ The burners are supplied for connection to two pipes fuel supply system.
- ▶ Connect the ends of the flexible pipes to the suction and return pipework using the supplied nipples.
- ▶ Make the electrical connections to the burner following the wiring diagrams included in the instruction handbook.
- ▶ Prime the pump by turning the motor (after checking rotation direction if it is a three phase motor).
- ▶ Adjust the gas train for first start
- ▶ On start up, check:
 - ▶ Pressure pump and valve unit regulator (to max. and min.)
 - ▶ Gas pressure at the combustion head (to max. and min. output)
 - ▶ Combustion quality, in terms of unburned substances and excess air.

BURNER ACCESSORIES



Nozzles type 60° B

The nozzles must be ordered separately. The following table shows the features and codes on the basis of the maximum required fuel output.



| Nozzles type 60° B | | | | | |
|--------------------|-------|----------------------------|-----------|-----------|----------------|
| Burner | GPH | Rated output (kg/h) Nozzle | | | Code |
| | | at 10 bar | at 12 bar | at 14 bar | |
| RLS 28 | 2,00 | 7,7 | 8,5 | 9,2 | 3042126 |
| RLS 28-38 | 2,50 | 9,6 | 10,6 | 11,5 | 3042140 |
| RLS 28-38-50 | 3,00 | 11,5 | 12,7 | 13,8 | 3042158 |
| RLS 28-38-50 | 3,50 | 13,5 | 14,8 | 16,1 | 3042162 |
| RLS 38-50 | 4,00 | 15,4 | 17 | 18,4 | 3042172 |
| RLS 38-50 | 4,50 | 17,3 | 19,1 | 20,7 | 3042182 |
| RLS 38-50-70 | 5,00 | 19,2 | 21,2 | 23 | 3042192 |
| RLS 50-70 | 5,50 | 21,1 | 23,3 | 25,3 | 3042202 |
| RLS 50-70 | 6,00 | 23,1 | 25,5 | 27,7 | 3042212 |
| RLS 50-70 | 6,50 | 25 | 27,6 | 30 | 3042222 |
| RLS 70-100 | 7,00 | 26,9 | 29,7 | 32,3 | 3042232 |
| RLS 70-100 | 7,50 | 28,8 | 31,8 | 34,6 | 3042242 |
| RLS 70-100 | 8,00 | 30,8 | 33,9 | 36,9 | 3042252 |
| RLS 70-100 | 8,50 | 32,7 | 36,1 | 39,2 | 3042262 |
| RLS 70-100-130 | 9,50 | 36,5 | 40,3 | 43,8 | 3042282 |
| RLS 70-100-130 | 10,00 | 38,4 | 42,4 | 46,1 | 3042292 |
| RLS 70-100-130 | 11,00 | 42,3 | 46,7 | 50,7 | 3042312 |
| RLS 100-130 | 12,00 | 46,1 | 50,9 | 55,3 | 3042322 |
| RLS 100-130 | 13,00 | 50 | 55,1 | 59,9 | 3042332 |
| RLS 100-130 | 14,00 | 53,8 | 59,4 | 64,5 | 3042352 |
| RLS 100-130 | 15,00 | 57,7 | 63,6 | 69,2 | 3042362 |
| RLS 100-130 | 16,00 | 61,5 | 67,9 | 73,8 | 3042382 |
| RLS 130 | 17,00 | 65,4 | 72,1 | 78,4 | 3042392 |

Extended heads

"Standard head" burners can be transformed into "extended head" versions, by using the special kit. The kits available for the various burners, giving the original and the extended lengths, are listed below.

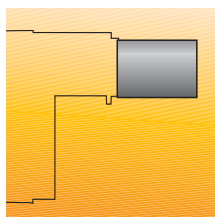

| Extended heads | | | |
|----------------|-----------------------------|-----------------------------|----------------|
| Burner | 'Standard' head length (mm) | 'Extended' head length (mm) | Kit code |
| RLS 28 | 191 | 326 | 3010154 |
| RLS 38 | 201 | 336 | 3010155 |
| RLS 50 | 216 | 351 | 3010156 |
| RLS 70 | 250 | 385 | 3010162 |
| RLS 100 | 250 | 385 | 3010163 |
| RLS 130 | 250 | 385 | 3010164 |



Degassing unit

To solve problem of air in the oil sucked, two versions of degassing unit are available.



| Degassing unit | | |
|----------------|------------------------------------|---------------------------------------|
| Burner | Degassing unit with filter Code | Degassing unit without filter Code |
| RLS | 3010055 | 3010054 |

Sound proofing box

If noise emission needs reducing even further, sound-proofing boxes are available, as given in the following table:



| Sound proofing box | | | |
|--------------------|----------|-------------------------------------|----------------|
| Burner | Box type | Average noise reduction [dB(A)] (*) | Box code |
| RLS 28 - 38 - 50 | C1/3 | 10 | 3010403 |
| RLS 70 - 100 - 130 | C4/5 | 10 | 3010404 |

(*) according to EN 15036-1 standard



GAS TRAIN ACCESSORIES



Seal control kit

To test the valve seals on the gas train, a special "seal control kit" is available.



| Seal control kit | | |
|------------------|---|----------------|
| Burner | Gas train | Kit code |
| RLS 28 | MBZRDLE 407 - MBZRDLE 410 - MBZRDLE 412 | 3010123 |
| | MBZRDLE 415 - MBZRDLE 420 - CB 40/2 - CB 50/2 | 3010125 |
| RLS 38 | MBZRDLE 410 - MBZRDLE 412 | 3010123 |
| | MBZRDLE 415 - MBZRDLE 420 - CB 40/2 - CB 50/2 | 3010125 |
| RLS 50 | MBZRDLE 410 - MBZRDLE 412 | 3010123 |
| | MBZRDLE 415 - MBZRDLE 420 - CB 40/2 - CB 50/2 | 3010125 |
| RLS 70 | MBZRDLE 415 - MBZRDLE 420 | 3010125 |
| | CB 40/2 - CB 50/2 - CBF 65/2 - CBF 80/2 | |
| RLS 100 | MBZRDLE 415 - MBZRDLE 420 | 3010125 |
| | CB 40/2 - CB 50/2 - CBF 65/2 - CBF 80/2 | |
| RLS 130 | MBZRDLE 415 - MBZRDLE 420 | 3010125 |
| | CB 40/2 - CB 50/2 - CBF 65/2 - CBF 80/2 | |

Stabiliser spring

Accessory springs are available to vary the pressure range of the gas train stabilisers.

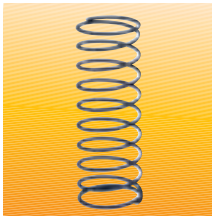







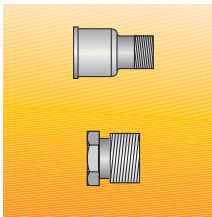

















| Stabiliser spring | | |
|---------------------|---------------------------|----------------|
| Gas train | Spring | Code |
| CBF 65/1 - CBF 80/1 | Red from 25 to 55 mbar | 3010133 |
| CBF 65/1 - CBF 80/1 | Black from 60 to 110 mbar | 3010135 |
| CBF 65/1 - CBF 80/1 | Pink from 90 to 150 mbar | 3090456 |

Adapters

When the diameter of the gas train is different from the set diameter of the burners, an adapter must be fitted between the gas train and the burner.



| Adapters | | | |
|----------|---|---|----------------|
| Burner | Gas train | Dimensions | Adapter code |
| RLS 28 | MBZRDLE 407 MBZRDLE 410 | 3/4"  1" 1/2 | 3000824 |
| | CB 50/2 - CB 50/2 CT MBZRDLE 420 MBZRDLE 420 CT | 2"  1" 1/2 | 3000822 |
| RLS 38 | MBZRDLE 410 | 3/4"  1" 1/2 | 3000824 |
| | MBZRDLE 420 MBZRDLE 420 CT | 2"  1" 1/2 | 3000822 |
| | CB 50/2 - CB 50/2 CT | | |
| RLS 50 | MBZRDLE 410 | 3/4"  1" 1/2 | 3000824 |
| | MBZRDLE 420 MBZRDLE 420 CT | 2"  1" 1/2 | 3000822 |
| | CB 50/2 - CB 50/2 CT | | |
| RLS 70 | MBZRDLE 415 - CB 40/2 | 1" 1/2  2" | 3000843 |
| | CBF 65/2 - CBF 65/2 CT | DN 65  2" 1/2  1" 1/2  2" | 3000825 |
| | CBF 80/2 - CBF 80/2 CT | DN 80  2" 1/2  2" | 3000826 |
| RLS 100 | MBZRDLE 415 - CB 40/2 | 1" 1/2  2" | 3000843 |
| | CBF 65/2 - CBF 65/2 CT | DN 65  2" 1/2  1" 1/2  2" | 3000825 |
| | CBF 80/2 - CBF 80/2 CT | DN 80  2" 1/2  2" | 3000826 |
| RLS 130 | MBZRDLE 415 - CB 40/2 | 1" 1/2  2" | 3000843 |
| | CBF 65/2 - CBF 65/2 CT | DN 65  2" 1/2  1" 1/2  2" | 3000825 |
| | CBF 80/2 - CBF 80/2 CT | DN 80  2" 1/2  2" | 3000826 |



SPECIFICATION

A specific index guides your choice of burner from the various models available in the RLS series. Below is a clear and detailed specification description of the product.

DESIGNATION OF SERIES

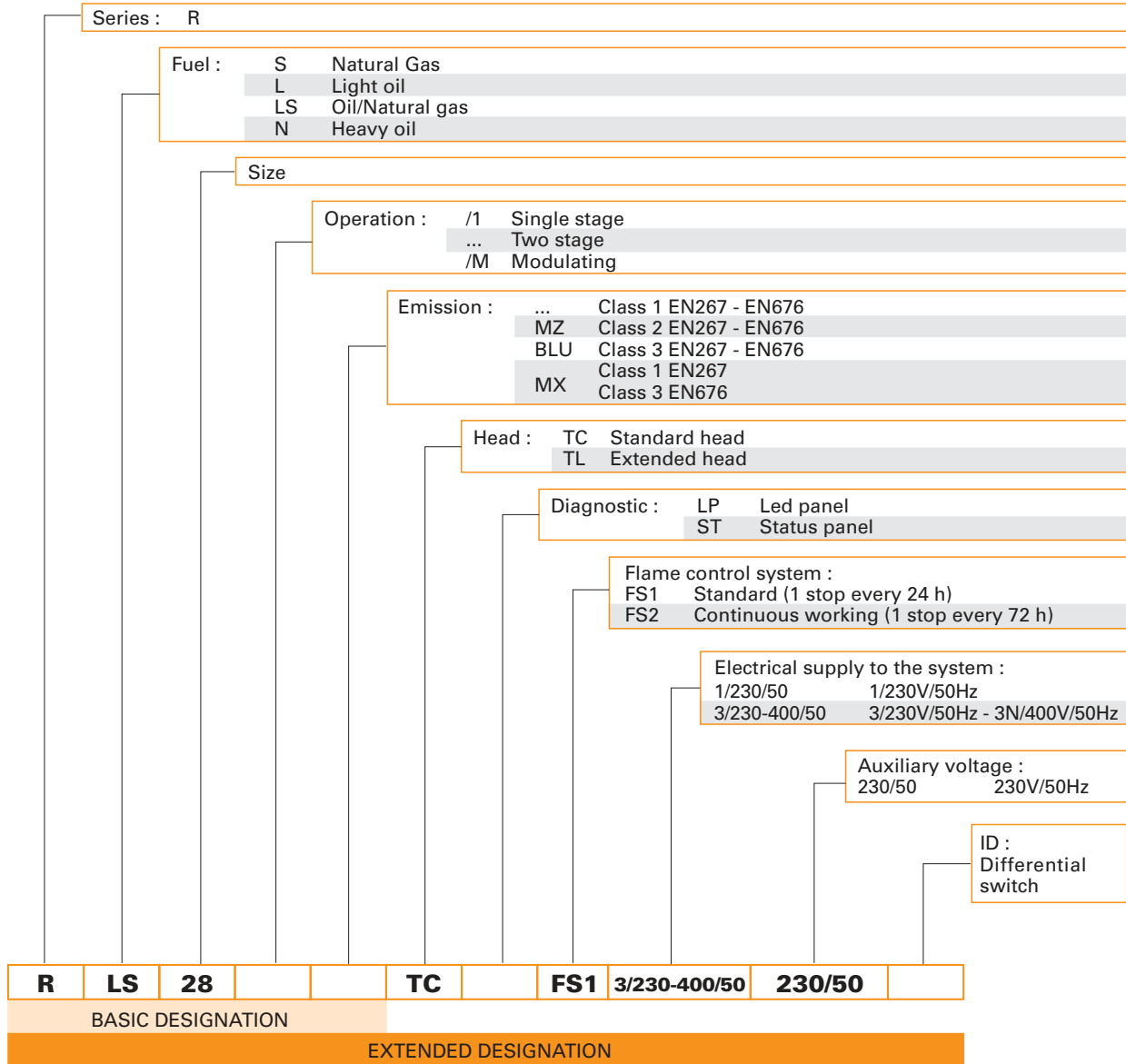

LIST OF AVAILABLE MODELS

| | | | | | |
|---------|----|----|-----|--------------|--------|
| RLS 28 | TC | LP | FS1 | 1/230/50 | 230/50 |
| RLS 38 | TC | LP | FS1 | 1/230/50 | 230/50 |
| RLS 50 | TC | LP | FS1 | 3/230-400/50 | 230/50 |
| RLS 70 | TC | LP | FS1 | 3/230-400/50 | 230/50 |
| RLS 100 | TC | LP | FS1 | 3/230-400/50 | 230/50 |
| RLS 130 | TC | LP | FS1 | 3/230-400/50 | 230/50 |

Other versions are available on request.



▶ **PRODUCT SPECIFICATION**

Burner:

Monobloc forced draught dual fuel burner, two stage operation, made up of:

- Air suction circuit lined with sound-proofing material
- Fan with reverse curve blades
- Fan starting motor
- Air damper for air setting controlled by a servomotor
- Minimum air pressure switch
- Combustion head, that can be set on the basis of required output
- Gears pump for high pressure fuel supply
- Pump starting motor
- Oil safety valves
- Two oil valves (1st and 2nd stage)
- Flame control panel
- Electronic device to check all burners operational modes (Led Panel)
- UV photocell for flame detection
- Burner on/off switch
- Oil/Gas selector
- Manual 1st and 2nd stage switch
- Plugs for electrical connections (RLS 28-38-50)
- Flame inspection window
- Slide bars for easier installation and maintenance
- Protection filter against radio interference
- IP 44 electric protection level.

Conforming to:

- 89/336/EC - 2004/108/EC directive (electromagnetic compatibility)
- 73/23/EC directive (low voltage)
- 92/42/EC directive (performance)
- 98/37/EC directive (machinery)
- EN 267 (liquid fuel burners)
- EN 676 (gas fuel burners).

Standard equipment:

- 1 gas train gasket
- 1 flange gasket
- 4 screws for fixing the flange
- 1 thermal screen
- 4 screws for fixing the burner flange to the boiler
- 2 flexible pipes for connection to the oil supply network
- 2 nipples for connection to the pump with gaskets
- Kit for transformation to LPG
- Fairleads for electrical connections (for RLS 28-38-50 model)
- Instruction handbook for installation, use and maintenance
- Spare parts catalogue.

Available accessories to be ordered separately:

- Nozzles
- Head extension kit
- Degasing unit
- Sound proofing box
- Adapters
- Stabiliser spring
- Seal control kit.



RIELLO S.p.A. - Via Ing. Pilade Riello, 5 - 37045 Legnago (VR) Italy

Tel. ++39.0442630111 - Fax ++39.044221980

Internet: <http://www.rielloburners.com> - E-mail: info@rielloburners.com

Since the Company is constantly engaged in the production improvement, the aesthetic and dimensional features, the technical data, the equipment and the accessories can be changed.

This document contains confidential and proprietary information of RIELLO S.p.A.
Unless authorised, this information shall not be divulged, nor duplicated in whole or in part.