

CE

**RIELLO**  
**B**  
**BURNERS**

## MODULATING DUAL FUEL BURNERS

▶ <b>ENNE/EMME SERIES</b>	▶ <b>ENNE/EMME 1400</b> 407/814 ÷ 1628 kW
	▶ <b>ENNE/EMME 2000</b> 581/1163 ÷ 2325 kW
	▶ <b>ENNE/EMME 3000</b> 872/1744 ÷ 3488 kW
	▶ <b>ENNE/EMME 4500</b> 1163/2325 ÷ 5000 kW

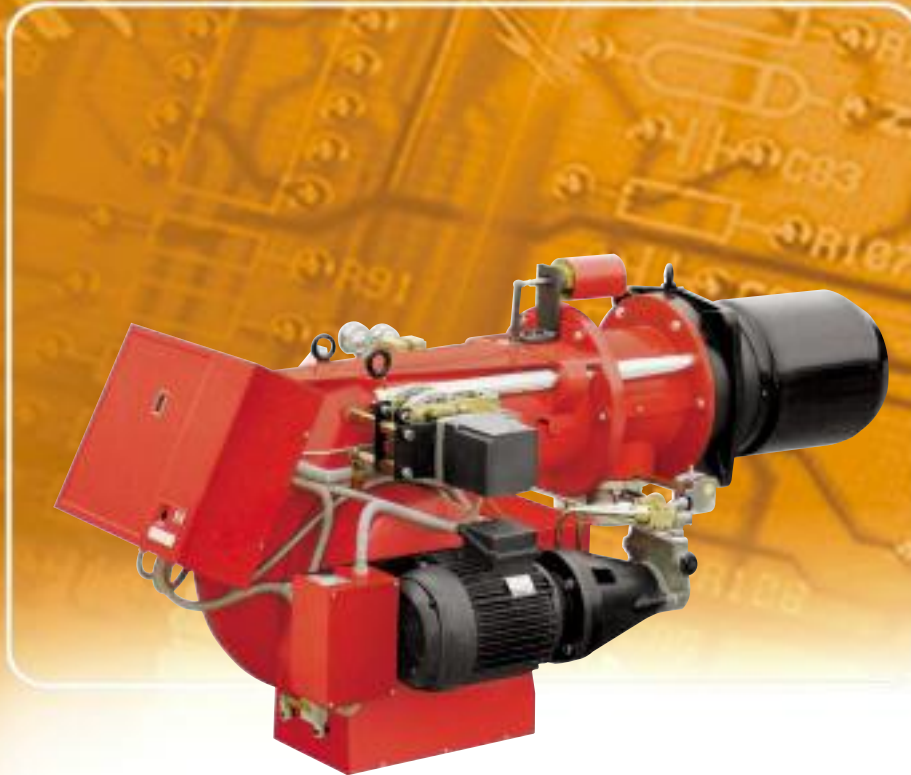

The ENNE/EMME 1400-4500 series of burners covers a firing range from 407 to 5000 kW. They have been designed for high output users and they are suitable for matching with every kind of boilers, with normal or pressurized combustion chamber. Operation can be "two stage progressive" or, alternatively, "modulating" with the installation of a PID logic regulator and respective probes. Two fuel options are available: only gas and only heavy oil, thus settable by a manual switch. Heavy oil circuit is fitted with his own electric motor: this permits pump stop during gas operation preventing danger of pumping seizure and avoiding oil circulation. A wide range of accessories and gas trains suitable to the burners guarantee an elevated working flexibility.

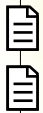

# TECHNICAL DATA

Model			▼ ENNE/EMME 1400	▼ ENNE/EMME 2000	▼ ENNE/EMME 3000	▼ ENNE/EMME 4500
Burner operation mode			Modulating (with regulator and probes accessories)			
Modulating ratio at max. output			3:1			
Servomotor	type	SQM 10.16502				
	run time	s	42			
Heat output	kW	407/814-1628	581/1163-2325	872/1744-3488	1163/2325-5000	
	Mcal/h	350/700-1400	500/1000-2000	750/1500-3000	1000/2000-4300	
Working temperature		°C min/max	0/40			
Oil	net calorific value	kWh/kg	11,16			
	viscosity	mm <sup>2</sup> /s (cSt)	max. 50 (at 50°C)			
	delivery	kg/h	36/73-114	52/104-208	78/156-312	104/208-448
Pump	type	TA 3		TA 4	NVBHR PDC	NVBHR MDC
	delivery	kg/h	750 (at 25 bar)	850 (at 25 bar)	900 (at 25 bar)	1200 (at 25 bar)
Atomised pressure		bar	25			
Fuel temperature		max °C	50			
Fuel pre-heater			YES			
G20	net calorific value	kWh/Nm <sup>3</sup>	10			
	density	kg/Nm <sup>3</sup>	0,71			
	gas delivery	Nm <sup>3</sup> /h	41/81-127	58/116-232	87/174-349	116/232-500
G25	net calorific value	kWh/Nm <sup>3</sup>	8,6			
	density	kg/Nm <sup>3</sup>	0,78			
	gas delivery	Nm <sup>3</sup> /h	47/95-147	68/135-270	101/203-406	135/270-581
LPG	net calorific value	kWh/Nm <sup>3</sup>	25,8			
	density	kg/Nm <sup>3</sup>	2,02			
	gas delivery	Nm <sup>3</sup> /h	16/32-49	23/45-90	34/68-135	45/90-194
Fan		type	Centrifugal with forward curve blades			
Air temperature		max °C	60			
Electrical supply		Ph / Hz / V	3N/50/230-400 (±10%) 3/50/230 (±10%) △			
Auxiliary electrical supply		Ph / Hz / V	1/50/230 (±10%)			
Control box		type	LFL 1.333			
Total electrical power		kW	19	20	32	35
Auxiliary electrical power		kW	0,9	0,9	1,2	1,2
Heaters electrical power		kW	14	14	19,6	19,6
Protection level		IP	40			
Pump motor electrical power		kW	1,1	1,1	2,2	2,2
Rated pump motor current		A	3 - 5,2	3 - 5,2	3,7 - 6,4	3,7 - 6,4
Pump motor start up current		A	--			
Pump motor protection level		IP	44			
Fan motor electrical power		kW	3	4	9	12
Rated fan motor current		A	6,1 - 10,6	8 - 13,8	17 - 29,4	26 - 45
Fan motor start up current		A	44,5 - 77	64 - 111	124,1 - 215	151 - 261
Fan motor protection level		IP	44	44	44	55
Ignition transformer		type	--			
		V1 - V2	230 V - 2 x 6 kV			
		I1 - I2	1,9 A - 35 mA			
Operation			Intermittent (at least one stop every 24h)			
Sound pressure		dB(A)				
Sound power		W				
Oil	CO emission	mg/kWh	< 170			
	Grade of smoke indicator	N° Bacharach	--			
	CxHy emission	mg/kWh	--			
	NOx emission	mg/kWh	< 1000			
G20	CO emission	mg/kWh	< 100			
	NOx emission	mg/kWh	< 150			
Directive			90/396 - 89/336 - 73/23 EEC			
Conforming to			EN 267 - EN 676			
Certification			--	--	--	--

Reference conditions:

Temperature: 20°C - Pressure: 1013,5 mbar - Altitude: 100 m a.s.l.

Noise measured at a distance of 1 meter.

Since the Company is constantly engaged in the production improvement, the aesthetic and dimensional features, the technical data, the equipment and the accessories can be changed.  
This document contains confidential and proprietary information of RIELLO S.p.A. Unless authorised, this information shall not be divulged, nor duplicated in whole or in part.



# FIRING RATES

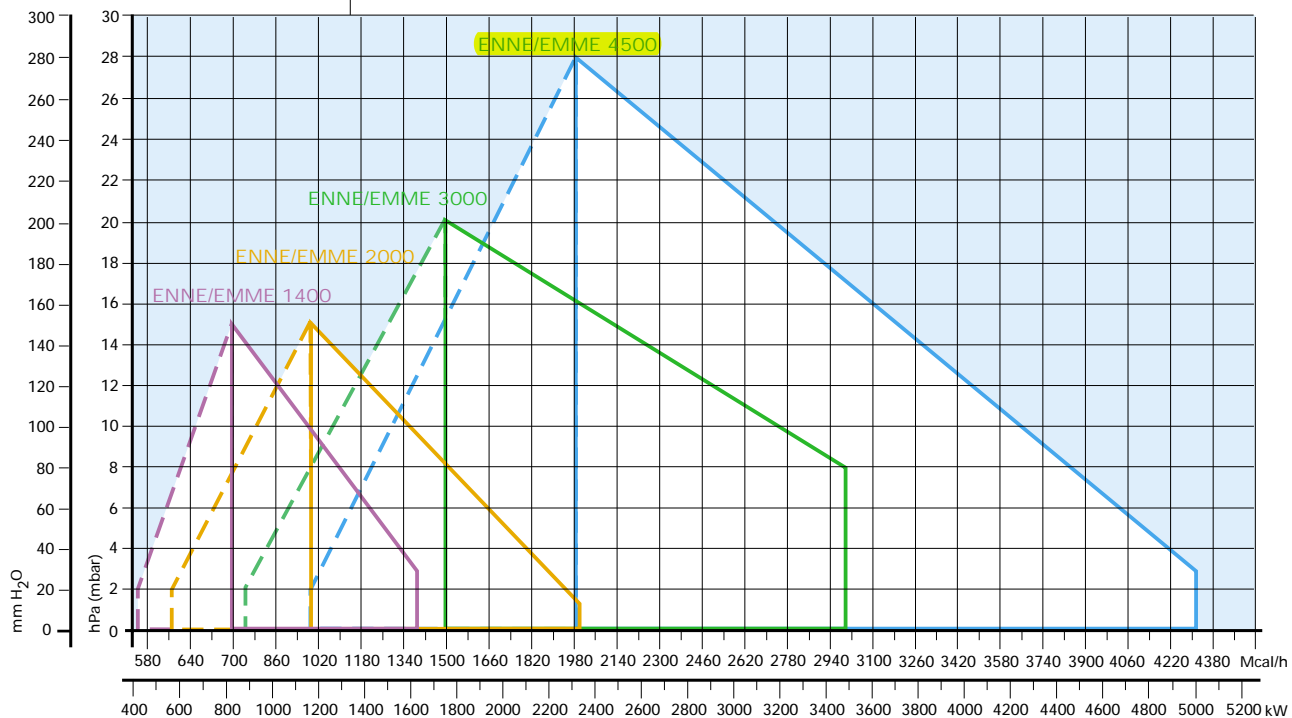

Useful working field for choosing the burner

Modulation range

Test conditions conforming to EN 267 - EN 676:  
 Temperature: 20°C  
 Pressure: 1013.5 mbar  
 Altitude: 100 m a.s.l.



# FUEL SUPPLY

## ▶ GAS TRAIN

The burners are fitted with a butterfly valve to regulate the fuel, controlled by a variable profile cam servomotor. Fuel can be supplied either from the right or left hand sides. A maximum gas pressure switch stops the burner in case of excess pressure in the fuel line.

The gas train can be selected to best fit system requirements depending on the fuel output and pressure in the supply line.

The gas train can be "Multibloc" type (containing the main components in a single unit) or "Composed" type (assembly of the single components).

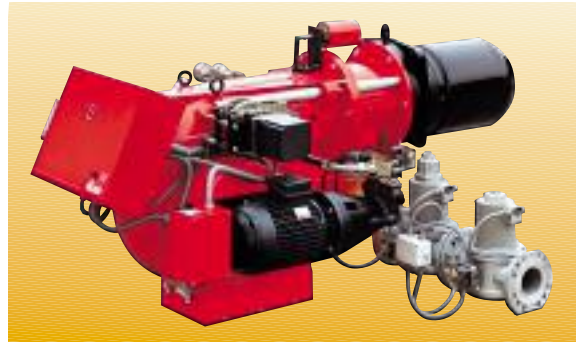

Example of burner of ENNE/EMME series with connected gas train

### MULTIBLOC gas train without seal control

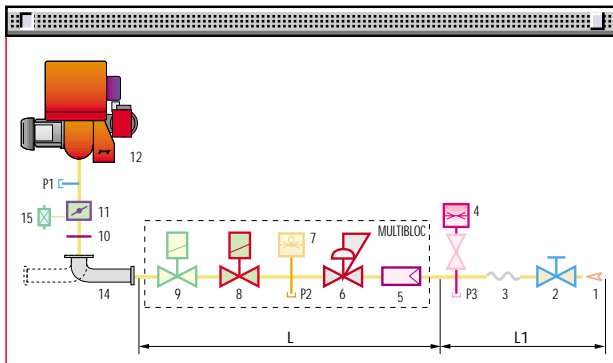

### MULTIBLOC gas train with seal control

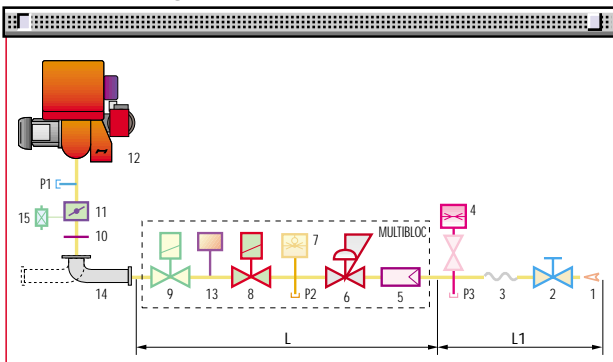

1	Gas input pipework
2	Manual valve
3	Anti-vibration joint
4	Pressure gauge with pushbutton cock
5	Filter
6	Pressure regulator (vertical)
7	Minimum gas pressure switch
8	VS safety solenoid (vertical)
9	VR regulation solenoid (vertical) Two settings: - firing output (rapid opening) - maximum output (slow opening)
10	Gasket and flange supplied with the burner
11	Gas adjustment butterfly valve
12	Burner
13	Seal control mechanism for valves 8-9. According to standard EN 676, the seal control is compulsory for burners with maximum output above 1200 kW
14	Gas train-burner adapter.
15	Maximum gas pressure switch
P1	Combustion head pressure
P2	Pressure downstream from the regulator
P3	Pressure upstream from the filter
L	Gas train supplied separately, with the code given in the table
L1	Installer's responsibility

### COMPOSED gas train without seal control

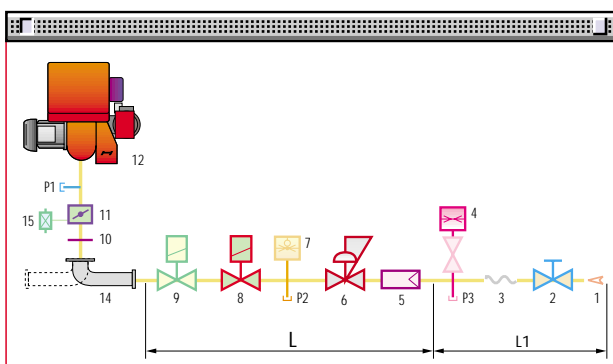

### COMPOSED gas train with seal control

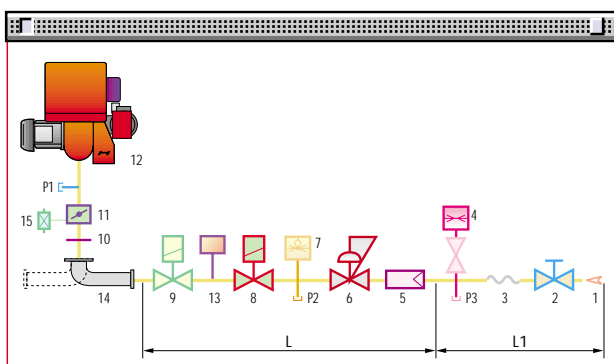

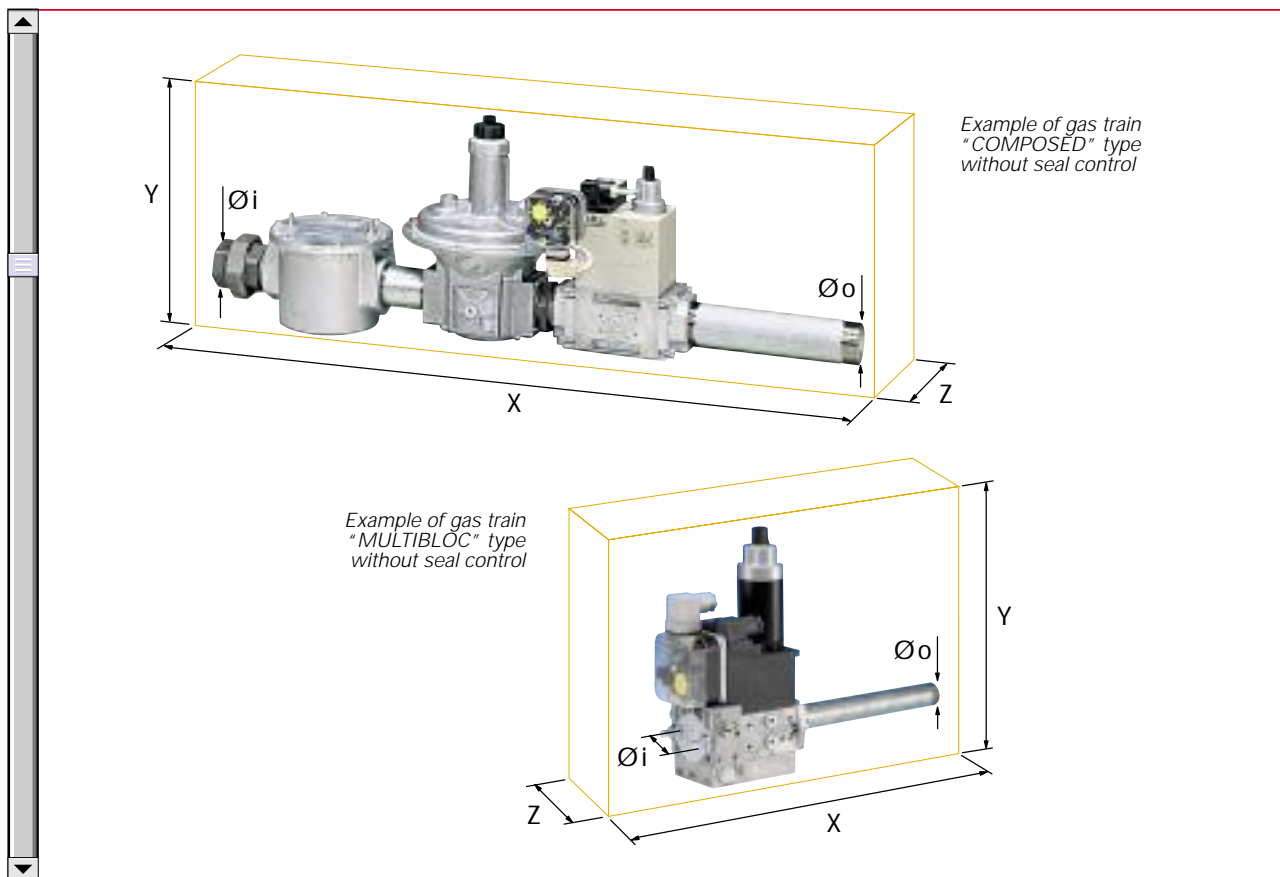

Gas trains are approved by standard EN 676 together with the burner.

The overall dimensions of the gas train depends on how they are constructed. The following table shows the maximum dimensions of the gas trains that can be fitted to ENNE/EMME burners, inlet and outlet diameters and seal control if fitted.

Please note that the seal control can be installed as an accessory, if not already installed on the gas train.

The maximum gas pressure of gas train "Multibloc" type is 300 mbar, and the one of the gas train "Composed" type is 500 mbar.

	Name	Code	Ø i	Ø o	X mm	Y mm	Z mm	SC
MULTIBLOC GAS TRAINS	<b>MBD 420</b>	3970181	2"	2"	523	300	100	-
	<b>MBD 420 CT</b>	3970182	2"	2"	523	300	227	Incorporated
COMPOSED GAS TRAINS	<b>CB 50/1</b>	3970146	2"	2"	986	328	250	-
	<b>CB 50/1 CT</b>	3970160	2"	2"	986	328	250	Incorporated
	<b>CBF 65/1</b>	3970147	DN 65	DN 65	874	356	285	-
	<b>CBF 65/1 CT</b>	3970161	DN 65	DN 65	874	356	285	Incorporated
	<b>CBF 80/1</b>	3970148	DN 80	DN 80	934	416	285	-
	<b>CBF 80/1 CT</b>	3970162	DN 80	DN 80	934	416	285	Incorporated
	<b>CBF 100/1</b>	3970149	DN 100	DN 100	1054	501	350	-
<b>CBF 100/1 CT</b>	3970163	DN 100	DN 100	1054	501	350	Incorporated	

When the diameter of the gas train is different from the set diameter of the burners, an adapter must be fitted between the gas train and the burner.

For further information see "Accessories" section.



## PRESSURE DROP DIAGRAM

The diagrams indicate the minimum pressure drop of the burners with the various gas trains that can be matched with them; at the value of these pressure drop add the combustion chamber pressure.

The value thus calculated represents the minimum required input pressure to the gas train.

### NATURAL GAS

#### ENNE/EMME 1400

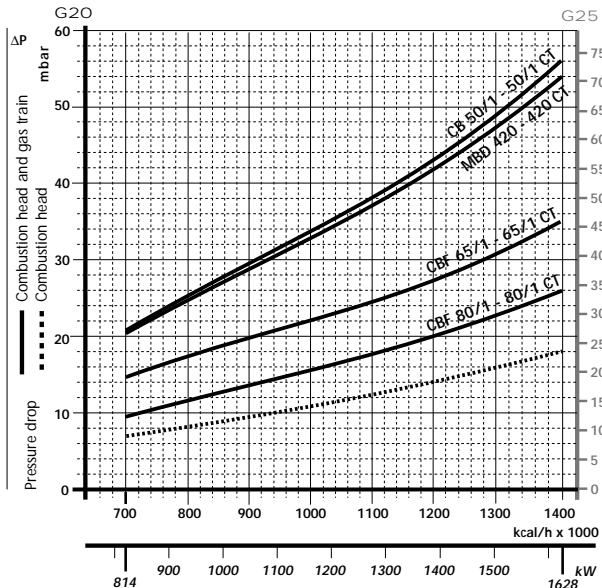

Gas train	Code	Adapter	Seal Control
MBD 420	3970181	-	Accessory
MBD 420 CT	3970182	-	Incorporated
CB 50/1	3970146	-	Accessory
CB 50/1 CT	3970160	-	Incorporated

### LPG

#### ENNE/EMME 1400

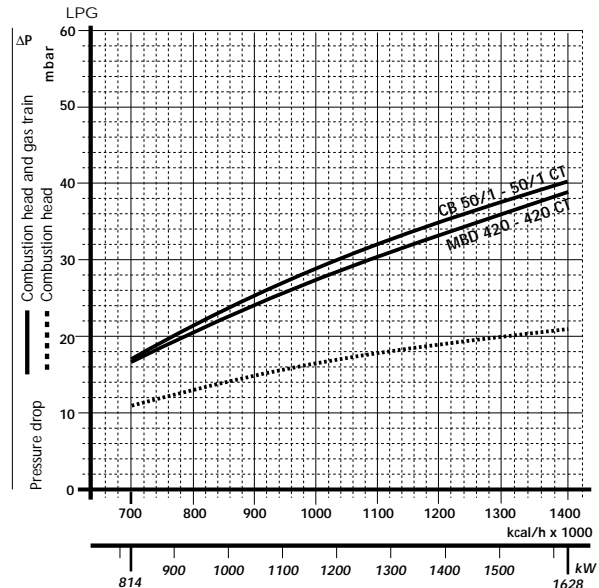

Gas train	Code	Adapter	Seal Control
CBF 65/1	3970147	3000825	Accessory
CBF 65/1 CT	3970161	3000825	Incorporated
CBF 80/1	3970148	3000826	Accessory
CBF 80/1 CT	3970162	3000826	Incorporated

#### ENNE/EMME 2000

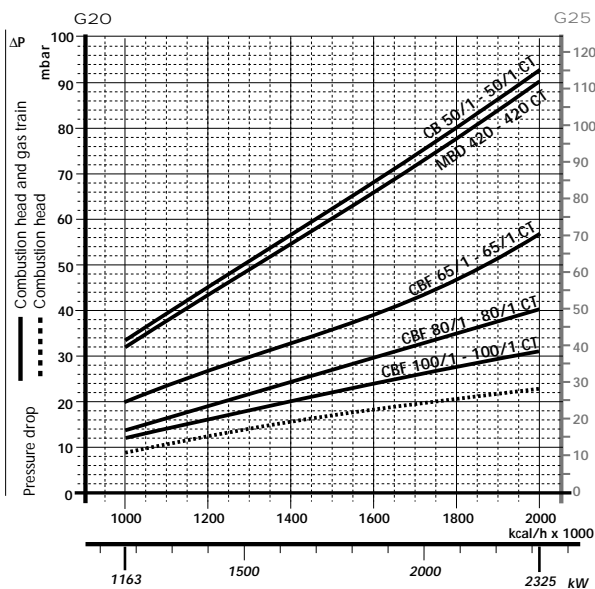

Gas train	Code	Adapter	Seal Control
MBD 420	3970181	-	Accessory
MBD 420 CT	3970182	-	Incorporated
CB 50/1	3970146	-	Accessory
CB 50/1 CT	3970160	-	Incorporated
CBF 65/1	3970147	3000825	Accessory

#### ENNE/EMME 2000

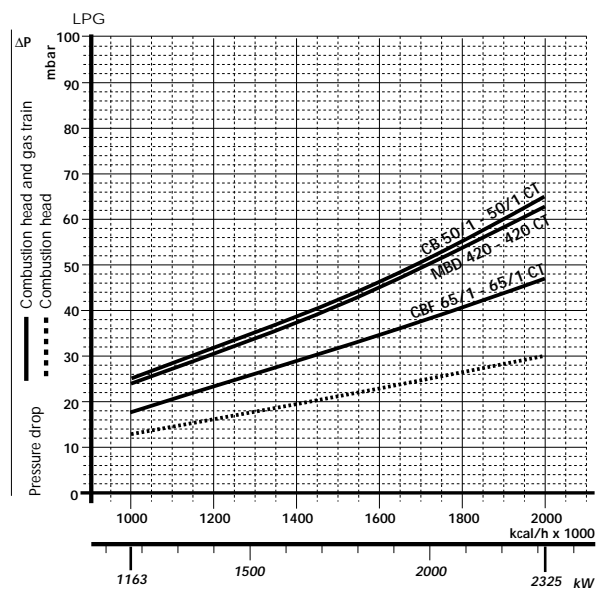

Gas train	Code	Adapter	Seal Control
CBF 65/1 CT	3970161	3000825	Incorporated
CBF 80/1	3970148	3000826	Accessory
CBF 80/1 CT	3970162	3000826	Incorporated
CBF 100/1	3970149	3010127	Accessory
CBF 100/1 CT	3970163	3010127	Incorporated



### NATURAL GAS

### LPG

#### ENNE/EMME 3000

#### ENNE/EMME 3000

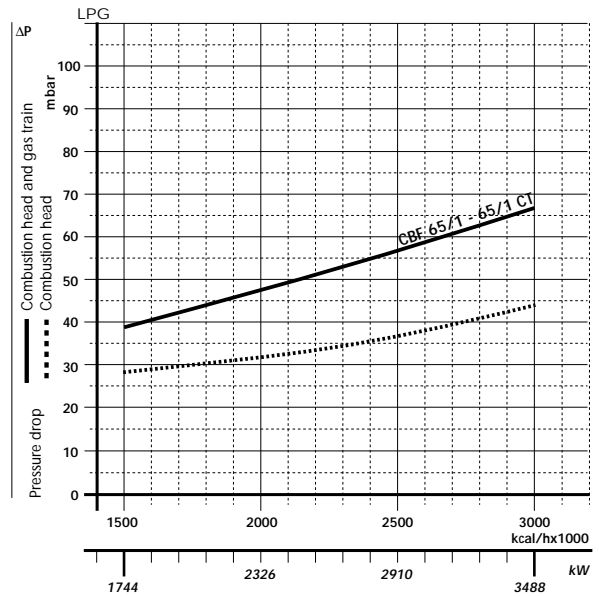
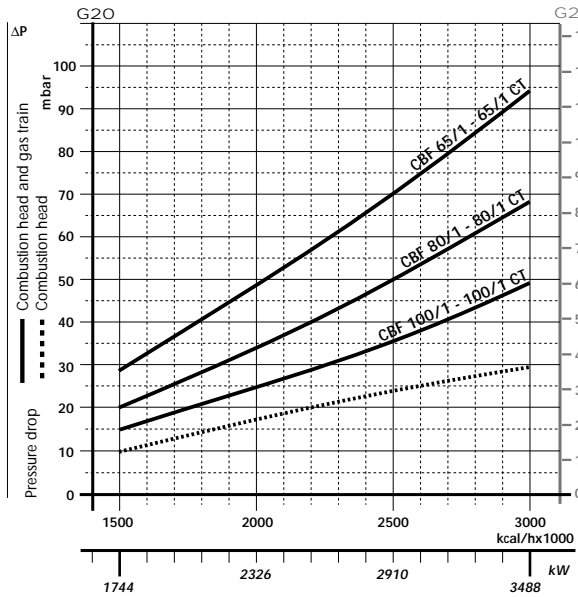

Gas train	Code	Adapter	Seal Control
CBF 65/1	3970147	3000831	Accessory
CBF 65/1 CT	3970161	3000831	Incorporated
CBF 80/1	3970148	3000832	Accessory

Gas train	Code	Adapter	Seal Control
CBF 80/1 CT	3970162	3000832	Incorporated
CBF 100/1	3970149	3010127	Accessory
CBF 100/1 CT	3970163	3010127	Incorporated

#### ENNE/EMME 4500

#### ENNE/EMME 4500

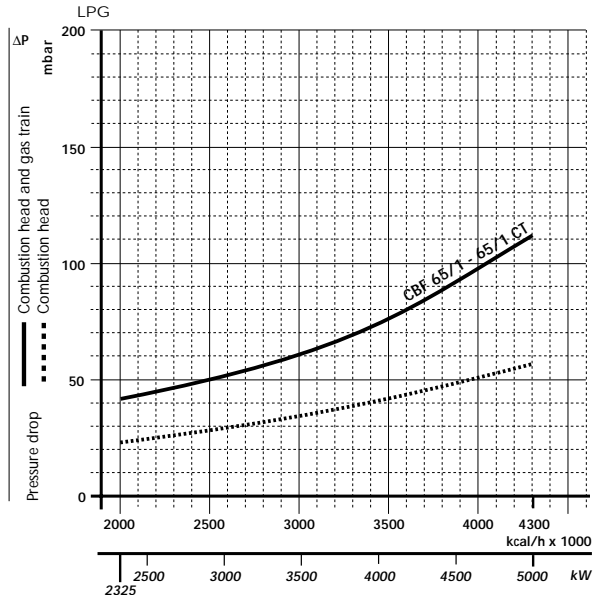
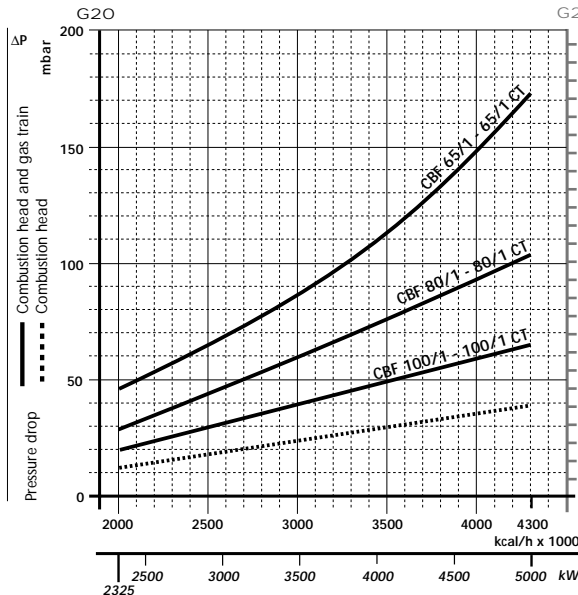

Gas train	Code	Adapter	Seal Control
CBF 65/1	3970147	3000831	Accessory
CBF 65/1 CT	3970161	3000831	Incorporated
CBF 80/1	3970148	3000832	Accessory

Gas train	Code	Adapter	Seal Control
CBF 80/1 CT	3970162	3000832	Incorporated
CBF 100/1	3970149	3010127	Accessory
CBF 100/1 CT	3970163	3010127	Incorporated

**note**

Please contact the Riello Burner Technical Office for different pressure levels from those above indicated.





## SELECTING THE FUEL SUPPLY LINES

The following diagram enables pressure drop in a pre-existing gas line to be calculated and to select the correct gas train.

The diagram can also be used to select a new gas line when fuel output and pipe length are known. The pipe diameter is selected on the basis of the desired pressure drop. The diagram uses methane gas as reference; if another gas is used, conversion coefficient and a simple formula (on the diagram) transform the gas output to a methane equivalent (refer to figure A). Please note that the gas train dimensions must take into account the back pressure of the combustion chamber during operations.

Control of the pressure drop in an existing gas line or selecting a new gas supply line. The methane output equivalent is determined by the formula fig. A on the diagram and the conversion coefficient.

Once the equivalent output has been determined on the delivery scale ( $\dot{V}$ ), shown at the top of the diagram, move vertically downwards until you cross the line that represents the pipe diameter; at this point, move horizontally to the left until you meet the line that represents the pipe length.

Once this point is established you can verify, by moving vertically downwards, the pipe pressure drop of on the bottom scale below (mbar).

By subtracting this value from the pressure measured on the gas meter, the correct pressure value will be found for the choice of gas train.

Example:

- gas used G25
- gas output 9.51 mc/h
- pressure at the gas meter 20 mbar
- gas line length 15 m
- conversion coefficient 0.62 (see figure A)

- equivalent methane output  $\dot{V} = \left[ \frac{9.51}{0.62} \right] = 15.34 \text{ mc/h}$

- once the value of 15.34 has been identified on the output scale ( $\dot{V}$ ), moving vertically downwards you cross the line that represents 1" 1/4 (the chosen diameter for the piping);

- from this point, move horizontally to the left until you meet the line that represents the length of 15 m of the piping;

- move vertically downwards to determine a value of 1.4 mbar in the pressure drop bottom scale;

- subtract the determined pressure drop from the meter pressure, the correct pressure level will be found for the choice of gas train;

- correct pressure = ( 20-1.4 ) = 18.6 mbar

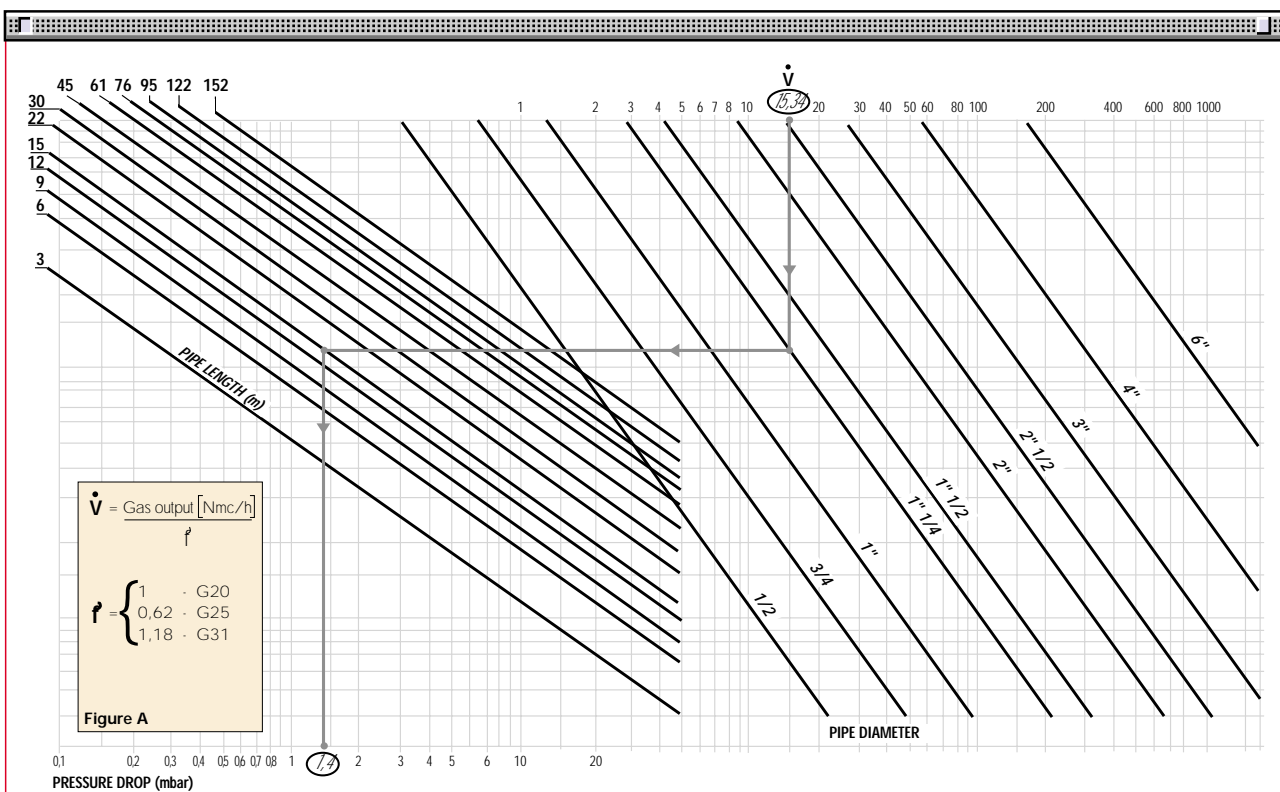





## ▶ HYDRAULIC CIRCUIT

The burners are fitted with two valves and an oil preheater with thermostats along the oil line from the pump to the nozzle, which opening is regulated from a needle valve. A pressure regulator on the return circuit from the nozzle allows to vary the quantity of fuel burnt.

For heavy oil preheating, a special kit with three electrical heaters at the pump, at the regulator and at the nozzle could be used.

The models are fitted with a maximum pressure switch on the oil return circuit.

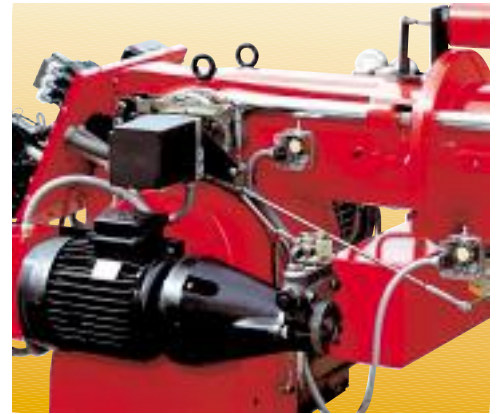

Example of oil circuit in ENNE/EMME series of burners

prEN 267 > 100 Kg/h

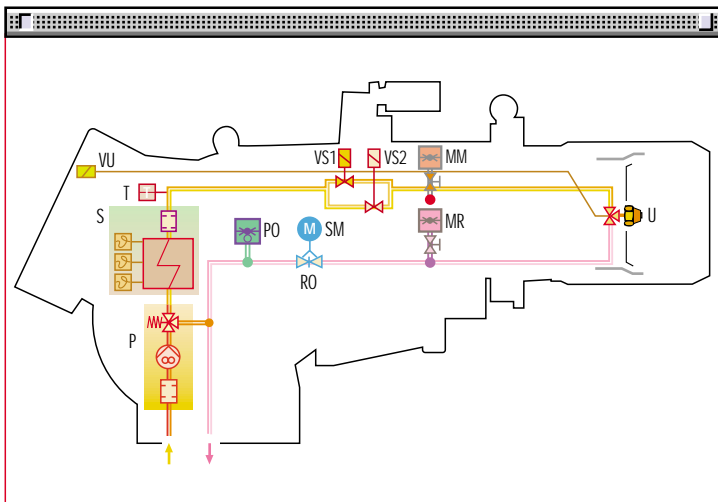

P	Pump with filter, heater and pressure regulator on the output circuit
S	Oil preheater with maximum, minimum and regulation thermostat
T	Thermometer
MM	Oil delivery gauge
SM	Servomotor
RO	Pressure regulator on the return circuit
PO	Oil pressure switch on the return circuit
U	Nozzle
MR	Pressure gauge on the return circuit
VU	Nozzle needle valve
VS <sub>n</sub>	Delivery oil valves

## SELECTING THE FUEL SUPPLY LINES

The fuel feed must be completed with the safety devices required by the local norms.

### IMPORTANT NOTES

- The oil could easily flow through the pipes if those are properly sized, protected and heated (by electricity, steam or hot water)
- In order to limit gas or steam production the oil pressure into the gas separator shall be set in function of the supply temperature, see instructions manual.
- The forwarding pump should have at least a double capacity than that one of the burner. For several burners supplied through the same ring supply line, the forwarding pump should have a capacity of approximatively 30% more than the sum of the single burners outputs.

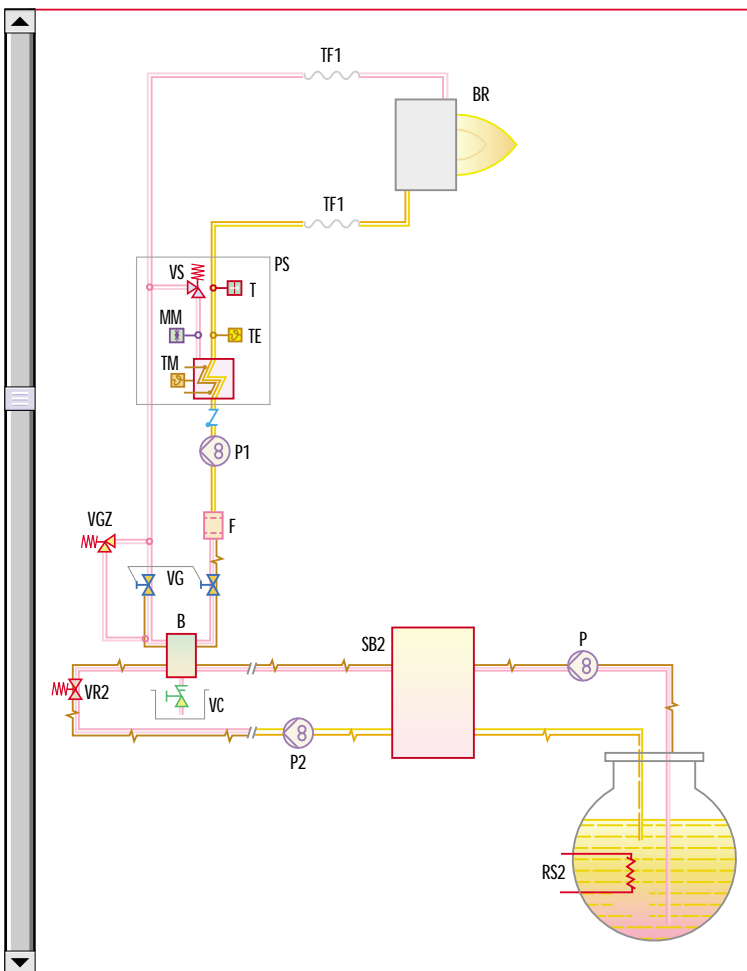

RS2	Tank heater
P	Double pumping unit with filter and heater on transfer ring
SB2	Service tank
P2	Double pumping unit with filter and heater on main ring
VR2	Oil valve - main ring
B	Gas separator bottle
VGZ	Safety valve - burner circuit
P1	Pump with heater - burner circuit
PS	Electrical preheater
VS	Preheater safety valve
BR	Burner
TF1	Flexible oil line
T	Thermometer
TM	Max oil temperature switch
TE	Temperature switch regulation
MM	Oil delivery gauge
VC	Vent valve
F	Oil filter

## VENTILATION

The ventilation circuit comes with a forward blades centrifugal fan, which guarantees high pressure levels at the required air deliveries and permits installation flexibility.

In spite of the remarkable output power and of the very high pressure performance, ENNE/EMME models are extremely compact.

Sound proofing boxes help to reduce the noise level.

A variable profile cam connects fuel and air setting, ensuring fuel efficiency at all firing rates.

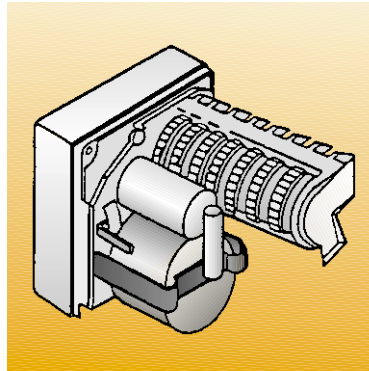

Example of servomotor mounted on ENNE/EMME series of burner



## COMBUSTION HEAD

Two different combustion head length can be selected for the various models of ENNE/EMME series of burners.

The choice depends on the thickness of the front panel and type of boiler. Correct head penetration into the combustion chamber depends on the type of heat generator.

These burners are equipped with a variable geometry combustion head. This enables optimum combustion performance throughout the working field, ensuring peak combustion efficiency thus saving on fuel consumption.

The following diagram shows the flame dimensions in relation to the burner output. The lengths and diameter shown in the diagram below should be employed for a preliminary check: if the combustion chamber dimensions are different from the values in the diagram, further tests need to be done.



Example of ENNE/EMME combustion head



### Flame dimensions

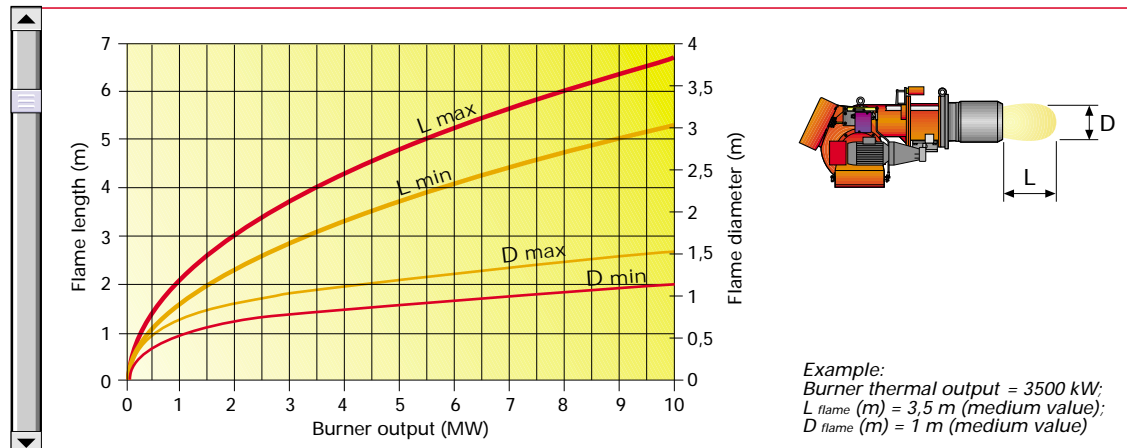



# ADJUSTMENT

## BURNER OPERATION MODE

The ENNE/EMME series of burners can be "two stage progressive" or "modulating".

During "two stage progressive" operation, the burner gradually adapts the output to the required level, by varying between two pre-set levels (see figure A).

During "modulating" operation, normally required in steam generators, in superheated water boilers or thermal oil boilers, a specific regulator and probes are required. These are supplied as accessories that must be ordered separately. The burner can work for long periods at intermediate output levels (see figure B).

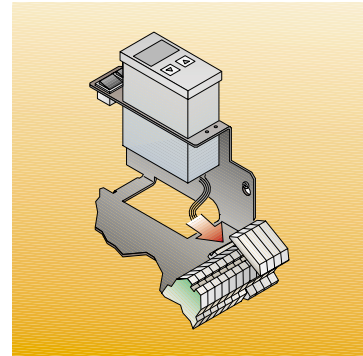

Example of a regulator

### "Two stage progressive" operation

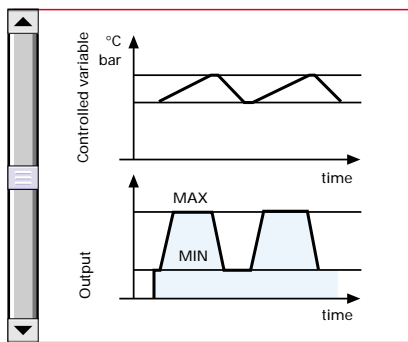

Figure A

### "Modulating" operation

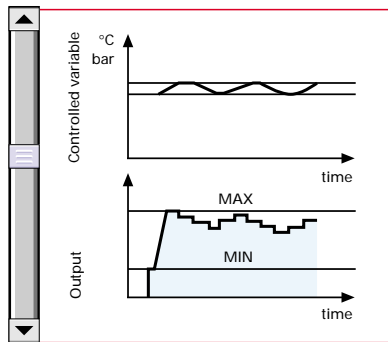
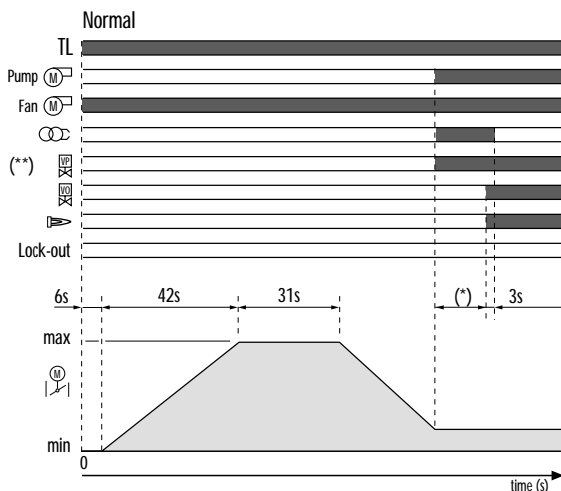

Figure B

## START UP CYCLE



- 0" The burner begins start-up cycle: fan motor starts turning.
- 6" - 48" The servomotor opens the air damper at the maximum position.
- 48" - 79" Chamber pre-purge phase with air damper open.
- 79" The servomotor takes the air damper to the firing position.
- n" Ignition transformer turns on. Pre-purge valve opens and oil circuit pre-purge phase takes place.
- n" + m" (\*) Ignition valve opens and flame rilevation with photocell is activated.
- n" + m" + 3" After a safety time of m" + 3" the ignition transformer turns off if there is the flame otherwise lock-out happens.

(\*) Time adjustable with timer (6" for gas working)  
 (\*\*) Only for heavy oil working.

# WIRING DIAGRAMS



Electrical connections must be made by qualified and skilled personnel, according to the local norms.

Example of the terminal board for the electrical connections for ENNE/EMME burner models

## “ TWO STAGE PROGRESSIVE ” OPERATION

### ENNE/EMME 1400 - 2000 - 3000 (direct start-up) - Without seal control

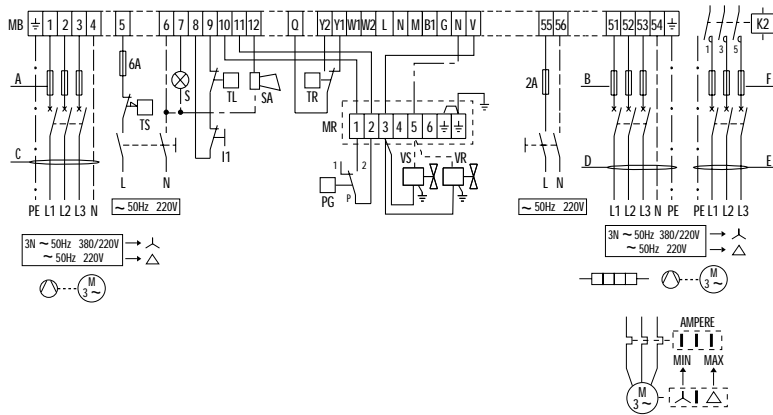

- I1 - Burner manual stop switch (optional)
- PG - Min. gas pressure switch
- S - Remote lock-out signal
- TR - High-low mode load remote control system
- TL - Load limit remote control system
- TS - Safety load control system
- VR - Regulating gas valve
- VS - Safety gas valve
- MB - Burner terminal board
- T6A - 6A Fuse
- F,B - Fuse
- L,H,D - Lead section
- SA - Oil high temperature alarm
- MR - Gas train terminal board
- K2 - Pump motor contactor

### ENNE/EMME 1400 - 2000 - 3000 (direct start-up) - With seal control

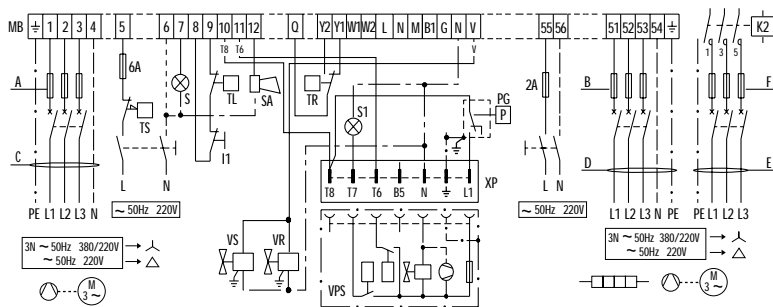

- I1 - Burner manual stop switch (optional)
- XP - Plug for seal control device
- PG - Min. gas pressure switch
- S - Remote lock-out signal
- S1 - Remote lock-out signal of seal control device
- TR - High-low mode load remote control system
- TL - Load limit remote control system
- TS - Safety load control system
- VR - Regulating gas valve
- VS - Safety gas valve
- MB - Burner terminal board
- VPS - Seal control valve
- T6A - 6A Fuse
- F,B - Fuse
- L,H,D - Lead section
- SA - Oil high temperature alarm
- K2 - Pump motor contactor

## ENNE/EMME 4500 (star delta start-up) - Without seal control

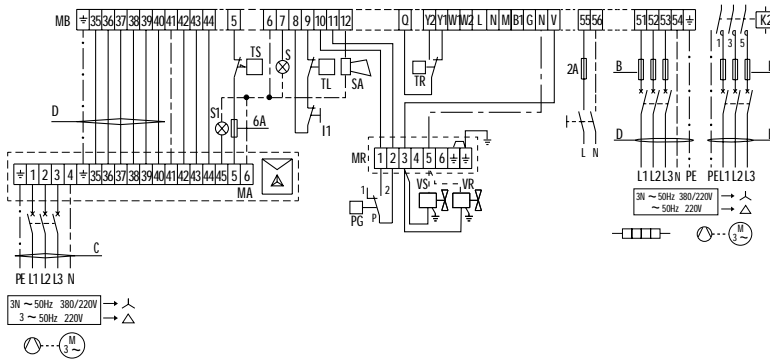

- I1 - Burner manual stop switch (optional)
- PG - Min. gas pressure switch
- S - Remote lock-out signal
- TR - High-low mode load remote control system
- TL - Load limit remote control system
- TS - Safety load control system
- VR - Regulating gas valve
- VS - Safety gas valve
- MB - Burner terminal board
- MA - Star delta starter terminal board
- S2 - Fan lock-out signal
- T6A - 6A Fuse
- F, B - Fuse
- L, H, D - Lead section
- SA - Oil high temperature alarm
- MR - Gas train terminal board
- K2 - Pump motor contactor

## ENNE/EMME 4500 (star delta start-up) - With seal control

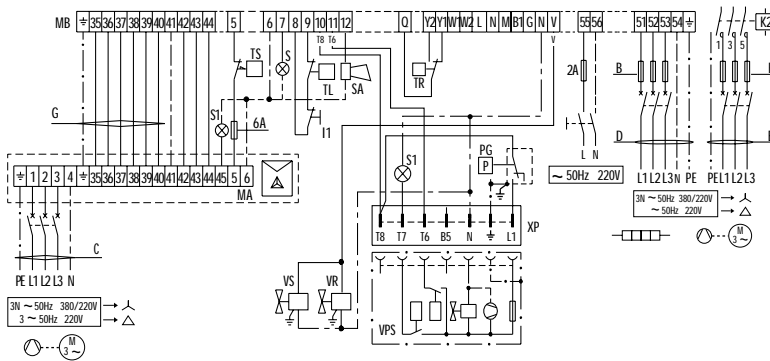

- I1 - Burner manual stop switch (optional)
- XP - Plug for seal control device
- PG - Min. gas pressure switch
- S - Remote lock-out signal
- S1 - Remote lock-out signal of seal control device
- TR - High-low mode load remote control system
- TL - Load limit remote control system
- TS - Safety load control system
- VR - Regulating gas valve
- VS - Safety gas valve
- MB - Burner terminal board
- VPS - Seal control device
- MA - Star delta starter terminal board
- S2 - Fan lock-out signal
- T6A - 6A Fuse
- F, B - Fuse
- L, H, D - Lead section
- SA - Oil high temperature alarm
- K2 - Pump motor contactor

## “MODULATING” OPERATION - temperature probe

### ENNE/EMME 1400 - 2000 - 3000 (direct start-up)

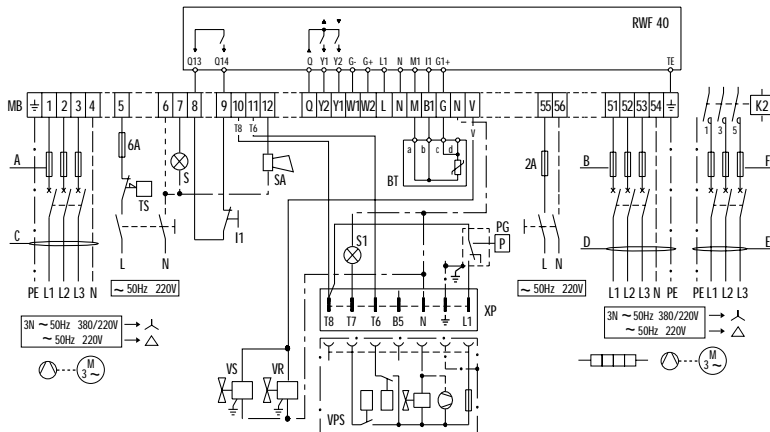

- I1 - Burner manual stop switch (optional)
- XP - Plug for seal control device
- PG - Min. gas pressure switch
- S - Remote lock-out signal
- S1 - Remote lock-out signal of seal control device
- TS - Safety load control system
- VR - Regulating gas valve
- VS - Safety gas valve
- MB - Burner terminal board
- VPS - Seal control device
- RWF 40 - Regulator (fitted to the burner)
- BT - Temperature probe
- T6A - 6A Fuse
- F, B - Fuse
- L, H, D - Lead section
- SA - Oil high temperature alarm
- K2 - Pump motor contactor



### ENNE/EMME 4500 (star delta start-up)

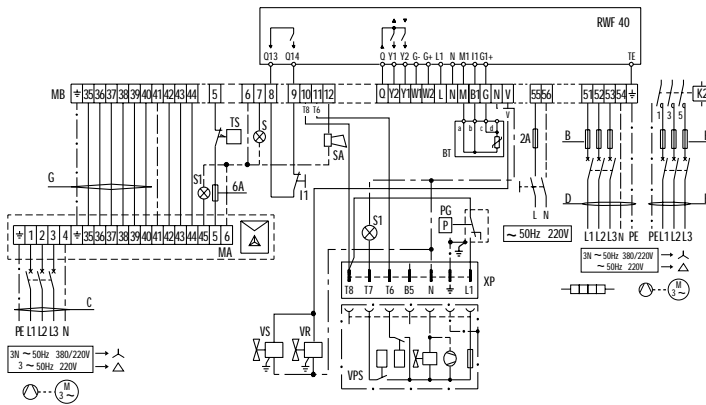

- I1 - Burner manual stop switch (optional)
- XP - Plug for seal control device
- PG - Min. gas pressure switch
- S - Remote lock-out signal
- S1 - Remote lock-out signal of seal control device
- TS - Safety load control system
- VR - Regulating gas valve
- VS - Safety gas valve
- MB - Burner terminal board
- VPS - Seal control device
- MA - Star delta starter terminal board
- S2 - Fan lock-out signal
- RWF 40 - Regulator (fitted to the burner)
- BT - Temperature probe
- T6A - 6A Fuse
- F,B - Fuse
- L,H,D - Lead section
- SA - Oil high temperature alarm
- K2 - Pump motor contactor

### “MODULATING” OPERATION - pressure probe

### ENNE/EMME 1400 - 2000 - 3000 (direct start-up)

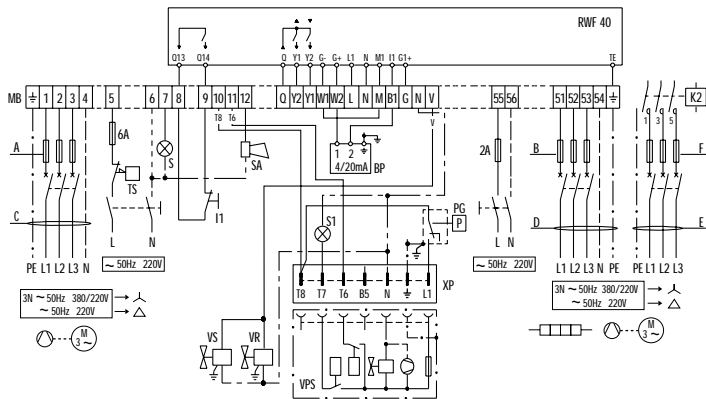

- I1 - Burner manual stop switch (optional)
- XP - Plug for seal control device
- PG - Min. gas pressure switch
- S - Remote lock-out signal
- S1 - Remote lock-out signal of seal control device
- TS - Safety load control system
- VR - Regulating gas valve
- VS - Safety gas valve
- MB - Burner terminal board
- VPS - Seal control device
- RWF 40 - Regulator (fitted to the burner)
- BP - Pressure probe
- T6A - 6A Fuse
- F,B - Fuse
- L,H,D - Lead section
- SA - Oil high temperature alarm
- K2 - Pump motor contactor

### ENNE/EMME 4500 (star delta start-up)

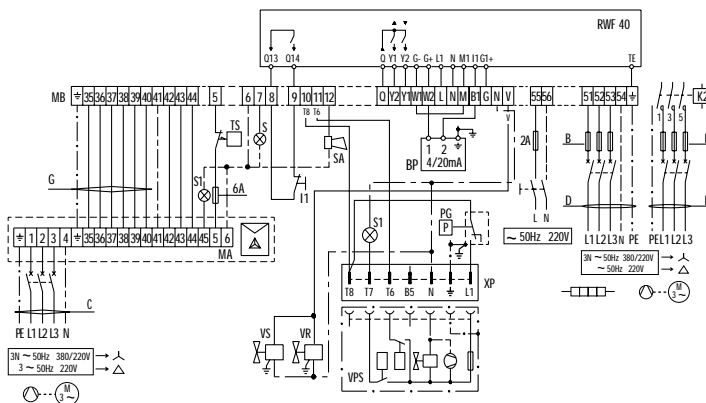

- I1 - Burner manual stop switch (optional)
- XP - Plug for seal control device
- PG - Min. gas pressure switch
- S - Remote lock-out signal
- S1 - Remote lock-out signal of seal control device
- TS - Safety load control system
- VR - Regulating gas valve
- VS - Safety gas valve
- MB - Burner terminal board
- VPS - Seal control device
- MA - Star delta starter terminal board
- S2 - Fan lock-out signal
- RWF 40 - Regulator (fitted to the burner)
- BP - Pressure probe
- T6A - 6A Fuse
- F,B - Fuse
- L,H,D - Lead section
- SA - Oil high temperature alarm
- K2 - Pump motor contactor

Model	Direct start-up				Star delta start-up			
	ENNE/EMME 1400	ENNE/EMME 2000	ENNE/EMME 3000	ENNE/EMME 4500	ENNE/EMME 1400	ENNE/EMME 2000	ENNE/EMME 3000	ENNE/EMME 4500
	230 V	400 V	230 V	400 V	230 V	400 V	230 V	400 V
A A	25	25	35	25	63	50	-	-
B A	50	35	50	35	63	50	63	50
F A	6	4	6	4	16	10	20	16
C mm <sup>2</sup>	2,5	2,5	4	2,5	6	4	10	6
D mm <sup>2</sup>	10	6	10	6	10	6	10	6
E mm <sup>2</sup>	2,5	1,5	2,5	1,5	4	2,5	4	2,5
G mm <sup>2</sup>	-	-	-	-	-	-	6	4

The following table shows the supply lead sections and the type of fuse to be used.





# EMISSIONS

### NO<sub>x</sub> EMISSIONS

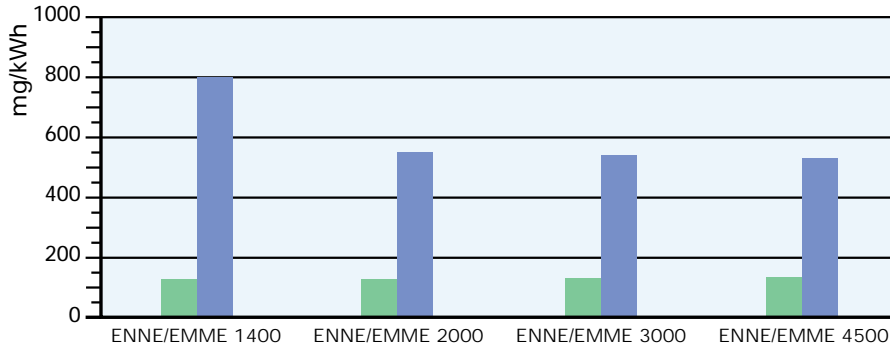

Gas working  
Heavy oil working

### CO EMISSIONS

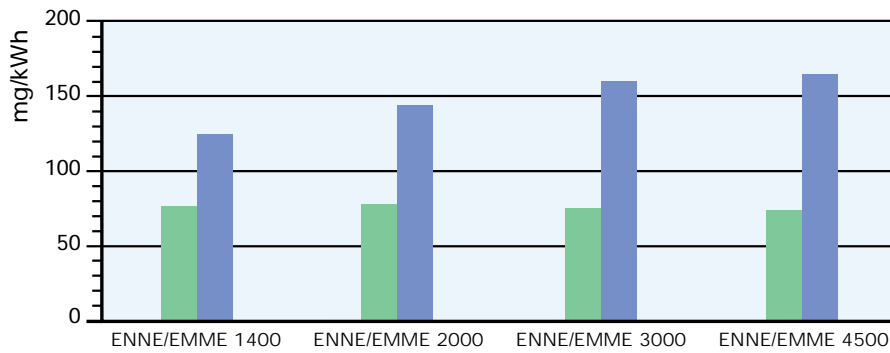

### NOISE EMISSIONS

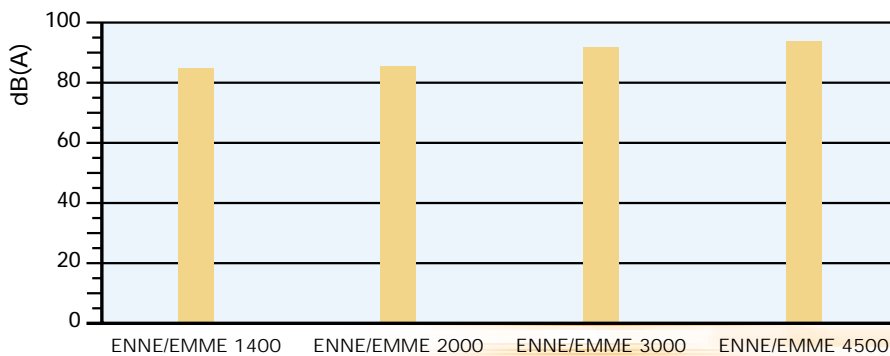

The emission data has been measured in the various models at maximum output, according to EN 676 and EN 267 standard.



## OVERALL DIMENSIONS (mm)



### BURNER

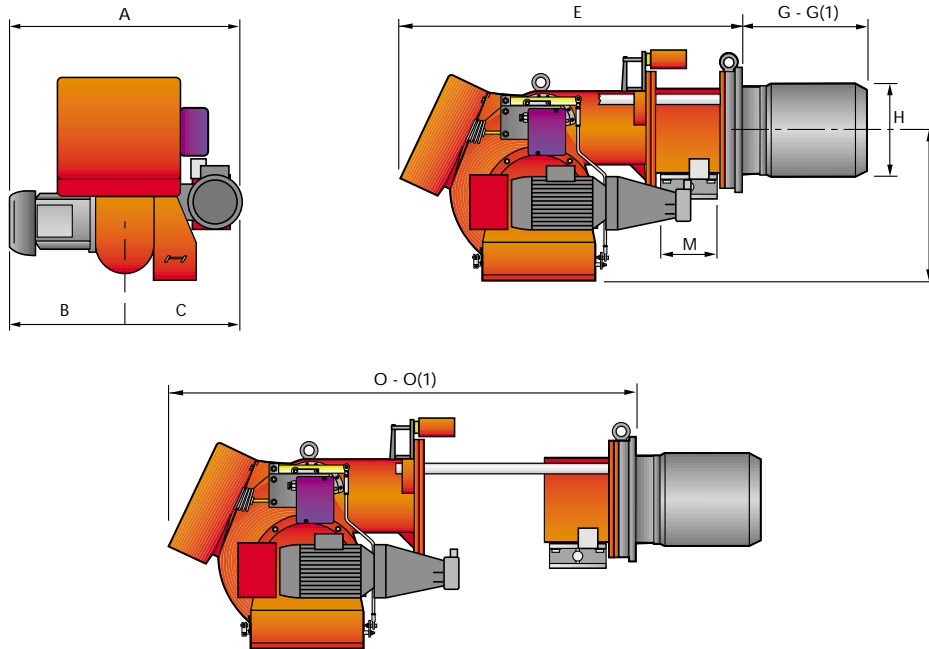

Model	A	B	C	E	G - G(1)	H	I	M	O - O(1)
▶ ENNE/EMME 1400	892	376	516	1090	385 - 495	250	467	2"	1475 - 1585
▶ ENNE/EMME 2000	912	396	516	1090	385 - 495	260	467	DN80	1475 - 1585
▶ ENNE/EMME 3000	1000	447	553	1320	476 - 606	336	525	DN80	1796 - 1926
▶ ENNE/EMME 4500	1061	508	553	1320	476 - 606	336	525	DN80	1796 - 1926

(1) model "extended head"

### BURNER - BOILER MOUNTING FLANGE

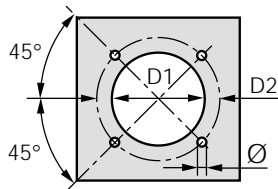

Model	D1	D2	Ø
▶ ENNE/EMME 1400	255	260	M16
▶ ENNE/EMME 2000	265	260	M16
▶ ENNE/EMME 3000	340	310	M20
▶ ENNE/EMME 4500	340	310	M20

### PACKAGING

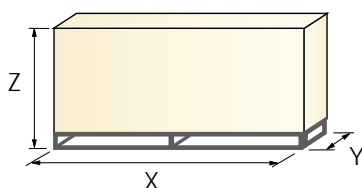

Model	X - X(1)	Y	Z	Kg
▶ ENNE/EMME 1400	1670 - 1670	1010	780	265
▶ ENNE/EMME 2000	1670 - 1670	1010	780	265
▶ ENNE/EMME 3000	2000 - 2000	1160	870	280
▶ ENNE/EMME 4500	2000 - 2000	1160	870	290



## INSTALLATION DESCRIPTION

Installation, start up and maintenance must be carried out by qualified and skilled personnel.  
All operations must be performed in accordance with the technical handbook supplied with the burner.

### ▶ BURNER SETTING

- ▶ All the burners have slide bars, for easier installation and maintenance.
- ▶ After drilling the boilerplate, using the supplied gasket as a template, dismantle the blast tube from the burner and fix it to the boiler.
- ▶ Adjust the combustion head.
- ▶ Fit the gas train choosing this on the basis of the maximum boiler output and following the diagrams included in the burner instruction handbook
- ▶ Refit the burner casing to the slide bars.
- ▶ Install the nozzle choosing this on the basis of the maximum boiler output and following the diagrams included in the burner instruction handbook.
- ▶ Check the position of the electrodes.
- ▶ Close the burner, sliding it up to the flange, keeping it slightly raised to avoid the flame stability disk rubbing against the blast tube.

### ▶ ELECTRICAL AND HYDRAULIC CONNECTIONS AND START UP

- ▶ The burners are supplied for connection to two pipes fuel supply system.
- ▶ Connect the ends of the flexible pipes to the suction and return pipework using the supplied nipples.
- ▶ Make the electrical connections to the burner following the wiring diagrams included in the instruction handbook.
- ▶ Prime the pump by turning the motor (after checking rotation direction if it is a three phase motor).
- ▶ Adjust the gas train for start-up  
On start-up, check:
  - Pressure pump and valve unit regulator (to max. and min.)
  - Gas pressure at the combustion head (to max. and min. output)
  - Combustion quality, in terms of unburned substances and excess air.

## BURNER ACCESSORIES

### Nozzles

The nozzles must be ordered separately. The following table shows the features and codes on the basis of the maximum required fuel output.



Nozzles type B3 - AA 45°		
Burner	Rated output (kg/h)	Nozzle code
ENNE/EMME 1400	70	3009613
ENNE/EMME 1400	80	3009615
ENNE/EMME 1400	90	3009617
ENNE/EMME 1400 - 2000	100	3009620
ENNE/EMME 1400 - 2000	125	3009623
ENNE/EMME 1400 - 2000 - 3000	150	3009626
ENNE/EMME 2000 - 3000	175	3009629
ENNE/EMME 2000 - 3000 - 4500	200	3009632
ENNE/EMME 3000 - 4500	225	3009635
ENNE/EMME 3000 - 4500	250	3009638
ENNE/EMME 3000 - 4500	275	3009641
ENNE/EMME 3000 - 4500	300	3009644
ENNE/EMME 4500	325	3009647
ENNE/EMME 4500	350	3009650
ENNE/EMME 4500	375	3009653
ENNE/EMME 4500	400	3009656
ENNE/EMME 4500	425	3009659
ENNE/EMME 4500	450	3009661

### Spacer kit

If burner head penetration into the combustion chamber needs reducing, varying thickness spacers are available, as given in the following list:

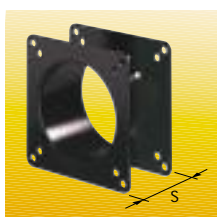

Spacer kit		
Burner	Spacer thickness S (mm)	Kit code
ENNE/EMME 1400 - 2000	110	3000722
ENNE/EMME 3000 - 4500	130	3000751

### Sound proofing box

If noise emission needs reducing even further, sound-proofing boxes are available, as given in the following table:



Sound proofing box		
Burner	Box type	Box code
ENNE/EMME 1400 - 2000	C7	3010048
ENNE/EMME 3000 - 4500	C8	3010049



## Accessories for modulating operation

To obtain modulating setting, the ENNE/EMME series of burners requires a regulator with three point outlet controls. The relative temperature or pressure probes fitted to the regulator must be chosen on the basis of the application.

The following table lists the accessories for modulating setting with their application range.



Burner	Regulator type	Code
ENNE/EMME 1400 - 2000 - 3000 - 4500	RWF 40	<b>3010211</b>



Probe type	Range (°C) (bar)	Probe code
Temperature PT 100	-100 ÷ 500°C	<b>3010110</b>
Pressure 4 ÷ 20 mA	0 ÷ 2,5 bar	<b>3010213</b>
Pressure 4 ÷ 20 mA	0 ÷ 16 bar	<b>3010214</b>

Depending on the servomotor fitted to the burner, a three-pole potentiometer (1000 Ω) can be installed to check the position of the servomotor. The KITS available for the various burners are listed below.



Burner	Potentiometer kit code
ENNE/EMME 1400 - 2000 - 3000 - 4500	<b>3010021</b>

## LPG kit

For burning LPG gas, a special kit is available to be fitted to the combustion head on the burner, as given in the following table:

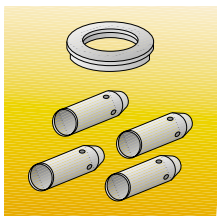

LPG kit		
Burner	Kit code for standard head	Kit code for extended head
ENNE/EMME 1400 - 2000	<b>3010063</b>	<b>3010063</b>

## GAS TRAIN ACCESSORIES

### Adapters

When the diameter of the gas train is different from the set diameter of the burners, an adapter must be fitted between the gas train and the burner. The following table lists the adapters for various burners.

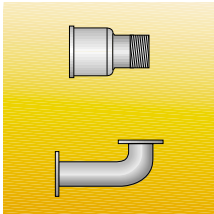

Adapters			
Burner	Gas train	Dimensions	Adapter code
ENNE/EMME 1400	CBF 65	 DN 65 2" 1/2 1" 1/2	3000825
	CBF 80	 DN 80 2" 1/2 2"	3000826
ENNE/EMME 2000	MBD 420 CB 50/1	 DN 80 DN 65 2" 1/2 2"	3010128
	CBF 65	 DN 65 DN 80	3000831
	CBF 80	 DN 80 DN 80	3000832
	CBF 100	 DN 100 DN 80	3010127
ENNE/EMME 3000	CBF 65	 DN 65 DN 80	3000831
	CBF 80	 DN 80 DN 80	3000832
	CBF 100	 DN 100 DN 80	3010127
ENNE/EMME 4500	CBF 65	 DN 65 DN 80	3000831
	CBF 80	 DN 80 DN 80	3000832
	CBF 100	 DN 100 DN 80	3010127

### Stabiliser spring

Accessory springs are available to vary the pressure range of the gas train stabilisers. The following table shows these accessories with their application range.

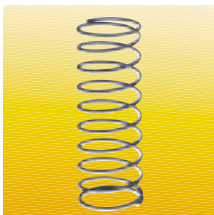

Stabiliser spring		
Gas train	Spring	Spring code
CBF 65/1 - CBF 80/1	Red from 25 to 55 mbar	3010133
CBF 100/1	Red from 25 to 55 mbar	3010134
CBF 65/1 - CBF 80/1	Black from 60 to 110 mbar	3010135
CBF 100/1	Black from 60 to 110 mbar	3010136
CBF 65/1 - CBF 80/1	Pink from 90 to 150 mbar	3090456
CBF 100/1	Pink from 90 to 150 mbar	3090489

## Seal control kit

To test the valve seals on the gas train, a special "seal control kit" is available. The valve seal control device is compulsory (EN 676) on gas trains to burners with a maximum output over 1200 kW. The seal control is type VPS 504.



Seal control kit		
Burner	Gas train	Kit code
ENNE/EMME 1400	MBD 420 - CB 50/1 - CBF 65/1 - CBF 80/1	<b>3010125</b>
ENNE/EMME 2000	MBD 420 - CB 50/1 - CBF 65/1 - CBF 80/1- CBF 100/1	<b>3010125</b>
ENNE/EMME 3000	CBF 65/1 - CBF 80/1- CBF 100/1	<b>3010125</b>
ENNE/EMME 4500	CBF 65/1 - CBF 80/1	<b>3010125</b>



## SPECIFICATION

A specific index guides your choice of burner from the various models available in the ENNE/EMME series. Below is a clear and detailed specification description of the product.

### DESIGNATION OF SERIES

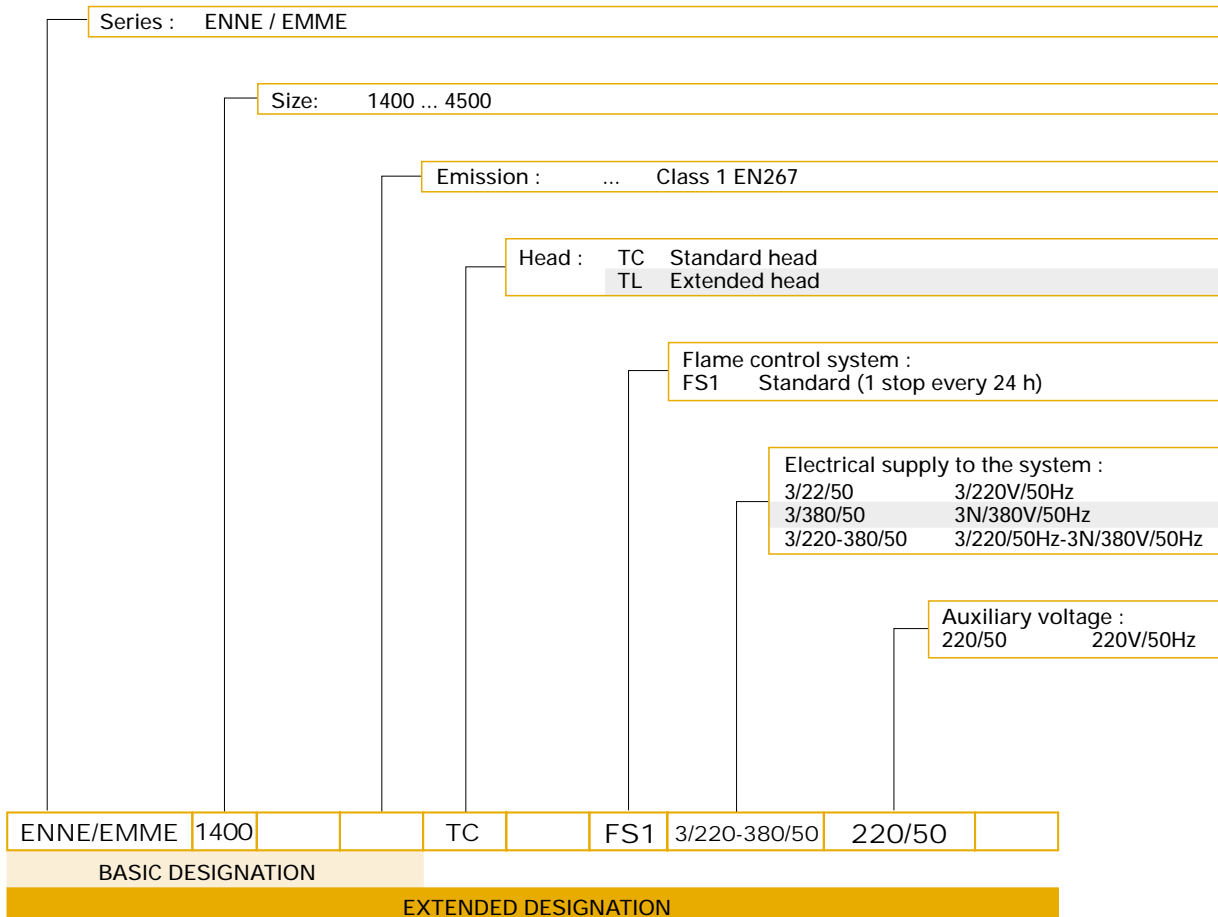



## AVAILABLE BURNER MODELS

ENNE/EMME 1400 TC	FS1	3/220-380/50	220/50	ENNE/EMME 4500 TC	FS1	3/220/50	220/50
ENNE/EMME 1400 TL	FS1	3/220-380/50	220/50	ENNE/EMME 4500 TL	FS1	3/220/50	220/50
ENNE/EMME 2000 TC	FS1	3/220-380/50	220/50	ENNE/EMME 4500 TC	FS1	3/380/50	220/50
ENNE/EMME 2000 TL	FS1	3/220-380/50	220/50	ENNE/EMME 4500 TL	FS1	3/380/50	220/50
ENNE/EMME 3000 TC	FS1	3/220-380/50	220/50	Other versions are available on request.			
ENNE/EMME 3000 TL	FS1	3/220-380/50	220/50				

## PRODUCT SPECIFICATION

### *Burner*

Monoblock forced draught dual fuel burner, two stage progressive or modulating operation with a kit, made up of:

- Air suction circuit
- Fan with forward curved blades
- Air damper for setting and butterfly valve for regulating fuel output controlled by a servomotor
- Combustion head, that can be set on the basis of required output
- Maximum gas pressure switch
- Minimum air pressure switch
- Fan electrical motor
- Pump electrical motor
- Gears pump for high pressure fuel supply, fitted with:
  - filter
  - pressure regulator
  - connections for installing a pressure gauge and a a vacuumeter
  - internal by-pass for sinlge pipe installation
- Preheater unit
- Valve unit with a double oil safety valve on the output circuit and safety valve on the return circuit
- UV photocell for flame detection
- Flame inspection window
- Slide bars for easier installation and maintenance
- Protection filter against radio interference
- IP 40 protection level.

### *Gas train*

Fuel supply line, in the MULTIBLOC configuration (from a diameter of 3/4" until a diameter 2") or COMPOSED configuration (from a diameter of DN 65 until a diameter of DN 100), fitted with:

- Filter
- Stabiliser
- Minimum gas pressure switch
- Safety valve
- Valve seal control (for output > 1200 kW)
- One stage working valve with ignition gas output regulator.

Conforming to:

- 90/396/EEC directive (gas)
- 89/336/EEC directive (electromagnetic compatibility)
- 73/23/EEC directive (low voltage)
- EN 267 (liquid fuel burners)
- EN 676 (gas fuel burners).

Standard equipment:

- 1 gas train gasket
- 12 screws for fixing the burner flange to the boiler
- 1 insulating screen
- 2 flexible hoses for connection to the oil supply circuit
- 2 nipples for connection to the pump
- 4 wiring looms fittings for electrical connections
- 2 pin extensions
- 8 washers
- Instruction handbook for installation, use and maintenance
- Spare parts catalogue.

Available accessories to be ordered separately:

- Return nozzles
- Head length reduction kit
- Sound proofing box
- RWF 40 output regulator
- Pressure probe 0-2,5 bar
- Pressure probe 0-16 bar
- Temperature probe -100-500°C
- Potentiometer kit for the servomotor
- Kit for transformation to LPG
- Gas train adapter
- Stabiliser spring
- Seal control kit.





RIELLO S.p.A. - Via degli Alpini, 1 - 37045 LEGNAGO (VR) Italy  
Tel. ++39.0442630111 - Fax ++39.044221980

Internet: <http://www.rielloburners.com> - E-mail: [rburners@rielloburners.com](mailto:rburners@rielloburners.com)

Since the Company is constantly engaged in the production improvement, the aesthetic and dimensional features, the technical data, the equipment and the accessories can be changed.  
This document contains confidential and proprietary information of RIELLO S.p.A.  
Unless authorised, this information shall not be divulged, nor duplicated in whole or in part.

