



MODULATING DUAL FUEL BURNERS

▶ **GI/EMME SERIES**

▶ GI/EMME 1400	407/820 ÷ 1540 kW
▶ GI/EMME 2000	581/1163 ÷ 2325 kW
▶ GI/EMME 3000	872/1744 ÷ 3488 kW
▶ GI/EMME 4500	1163/2350 ÷ 4650 kW



The GI/EMME 1400-4500 series of burners covers a firing range from 407 to 4650 kW. They have been designed for high output users and they are suitable for matching with all kinds of boilers, with normal or pressurized combustion chamber.

Operation can be "two stage progressive" or, alternatively, "modulating" with the installation of a PID logic regulator and probes. Two operating options, gas or light oil, are available at the touch of a switch. The light oil circuit comes with its own electric motor: so the pump is stopped during gas operation to prevent pump seizure and to avoid oil in circulation. A wide range of accessories and gas trains guarantee maximum working flexibility.

TECHNICAL DATA

Model		▼ GI/EMME 1400	▼ GI/EMME 2000	▼ GI/EMME 3000	▼ GI/EMME 4500
Burner operation mode		Modulating (with regulator and probes accessories) or two stage progressive			
Modulating ratio at max. ouput		3:1			
Servomotor	type	SQM 10.16502			
	run time	s 42			
Heat output	kW	407/820-1540	581/1163-2325	872/1744-3488	1163/2350-4650
	Mcal/h	350/705-1324	500/1000-2000	750/1500-3000	1000/2021-4000
Working temperature		°C min/max 0/40			
Oil	Net calorific value	kWh/kg 11,8			
	Viscosity	mm ² /s (cSt) 4-6 (at 20°C)			
	Delivery	kg/h 34/69-130	kg/h 49/99-197	kg/h 74/148-296	kg/h 99/199-394
Pump	type	TA2	TA3	TA4	TA5
	delivery	kg/h 336 (at 25 bar)	kg/h 546 (at 25 bar)	kg/h 706 (at 25 bar)	kg/h 1008 (at 25 bar)
Atomised pressure		bar 25			
Fuel temperature		max °C 60			
Fuel preheater		NO			
G20	Net calorific value	kWh/Nm ³ 10			
	Density	kg/Nm ³ 0,71			
	Gas delivery	Nm ³ /h 41/82-154	Nm ³ /h 58/116-232,5	Nm ³ /h 87/174-349	Nm ³ /h 116/235-465
G25	Net calorific value	kWh/Nm ³ 8,6			
	Density	kg/Nm ³ 0,78			
	Gas delivery	Nm ³ /h 47/95-179	Nm ³ /h 68/135-270	Nm ³ /h 101/203-406	Nm ³ /h 135/273-541
LPG	Net calorific value	kWh/Nm ³ 25,8			
	Density	kg/Nm ³ 2,02			
	Gas delivery	Nm ³ /h 16/32-60	Nm ³ /h 23/45-90	Nm ³ /h 34/68-135	Nm ³ /h 45/91-180
Fan		type Centrifugal with reverse curve blades			
Air temperature		max °C 60			
Electrical supply		Ph / Hz / V 3N/50/230-400 (±10%)			
Auxiliary electrical supply		Ph / Hz / V 1/50/230 (±10%)			
Control box		type LFL 1.333			
Total electrical power		kW 5,1	kW 6,1	kW 12	kW 15,5
Auxiliary electrical power		kW 1	kW 1	kW 1,5	kW 2
Heaters electrical power		kW --			
Protection level		IP 44			
Pump motor electrical power		kW 1,1	kW 1,1	kW 1,5	kW 1,5
Rated pump motor current		A 3	A 3	A 3,7	A 3,7
Pump motor start up current		A --			
Pump motor protection level		IP 44			
Fan motor electrical power		kW 3	kW 4	kW 9	kW 12
Rated fan motor current		A 6,1	A 8	A 17	A 23
Fan motor start up current		A 44,5	A 64	A 124,1	A 158,7
Fan motor protection level		IP 44			
Ignition transformer		type --			
		V1- V2 230 V - 2 x 6 kV			
		I1 - I2 1,9 A - 35 mA			
Operation		Intermittent (at least one stop every 24h)			
Sound pressure		dB(A) 85,4	dB(A) 88	dB(A) 92	dB(A) 93,1
Sound power		W --			
Oil	CO emission	mg/kWh < 50			
	Grade of smoke indicator	N° Bacharach < 1			
	CxHy emission	mg/kWh --			
	NOx emission	mg/kWh < 250			
G20	CO emission	mg/kWh < 100			
	NOx emission	mg/kWh < 150			
Directive		90/396 - 89/336 - 73/23 EEC			
Conforming to		EN 267 - EN 676			
Certification		CE 0085AQ0712 DIN 5G830/97 M	CE 0085AQ0712 DIN 5G831/97 M	CE 0085AQ0712 DIN 5G832/97 M	CE 0085AQ0712 DIN 5G833/97 M

Reference conditions:

Temperature: 20°C - Pressure: 1013,5 mbar - Altitude: 100 m a.s.l.

Noise measured at a distance of 1 meter.

Since the Company is constantly engaged in the production improvement, the aesthetic and dimensional features, the technical data, the equipment and the accessories can be changed.
This document contains confidential and proprietary information of RIELLO S.p.A. Unless authorised, this information shall not be divulged, nor duplicated in whole or in part.



FIRING RATES

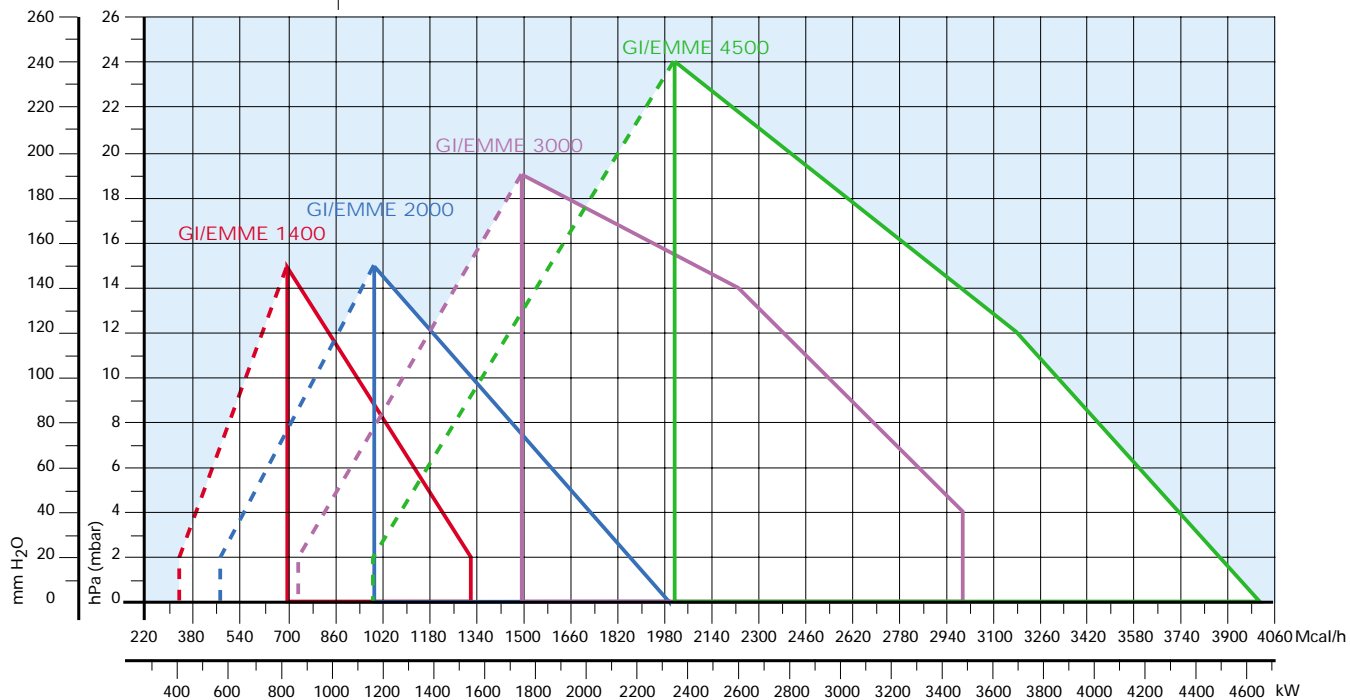

 Useful working field for choosing the burner

 Modulation range

Test conditions conforming to EN 267 - EN 676:
Temperature: 20°C
Pressure: 1013.5 mbar
Altitude: 100 m a.s.l.



FUEL SUPPLY

▶ GAS TRAIN

The burners are fitted with a butterfly valve to regulate the fuel, controlled by a variable profile cam servomotor. Fuel can be supplied either from the right or left hand sides, on the basis of the application requirements.

A maximum gas pressure switch stops the burner in case of an excess of pressure in fuel line.

The gas train can be selected to best fit system requirements depending on the fuel output and pressure in the supply line.

The gas train can be "Multibloc" type (containing the main components in a single unit) or "Composed" type (assembly of the single components).

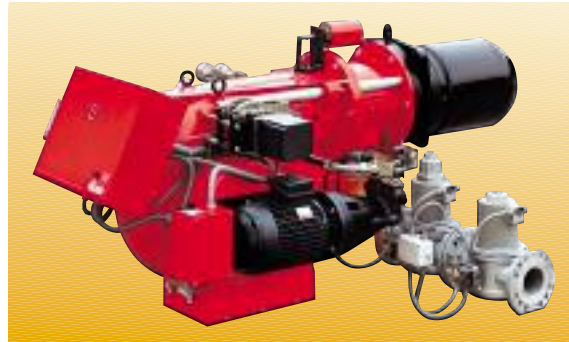

Example of burner of GI/EMME series with connected gas train

MULTIBLOC gas train without seal control

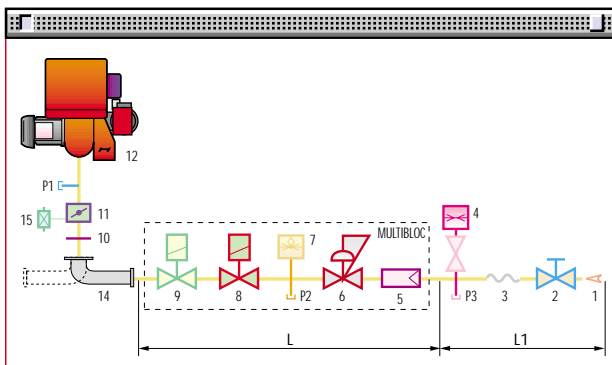

1	Gas input pipework
2	Manual valve
3	Anti-vibration joint
4	Pressure gauge with pushbutton cock
5	Filter
6	Pressure regulator (vertical)
7	Minimum gas pressure switch
8	VS safety solenoid (vertical)
9	VR regulation solenoid (vertical) Two settings: - firing output (rapid opening) - maximum output (slow opening)
10	Gasket and flange supplied with the burner
11	Gas adjustment butterfly valve
12	Burner
13	Seal control mechanism for valves 8-9. According to standard EN 676, the seal control is compulsory for burners with maximum output above 1200 kW
14	Gas train-burner adapter.
15	Maximum gas pressure switch
P1	Combustion head pressure
P2	Pressure downstream from the regulator
P3	Pressure upstream from the filter
L	Gas train supplied separately, with the code given in the table
L1	Installer's responsibility

MULTIBLOC gas train with seal control

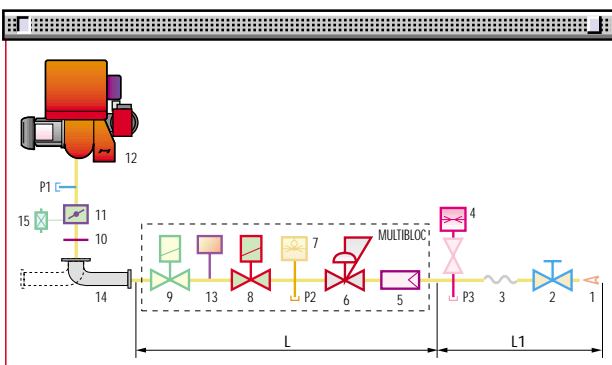

COMPOSED gas train without seal control

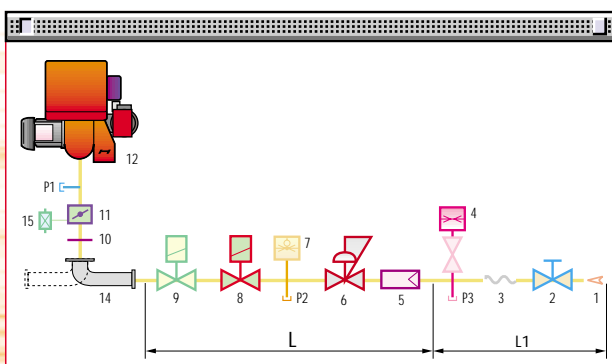

COMPOSED gas train with seal control

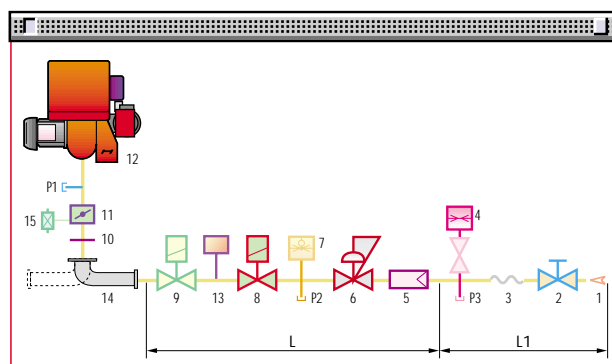

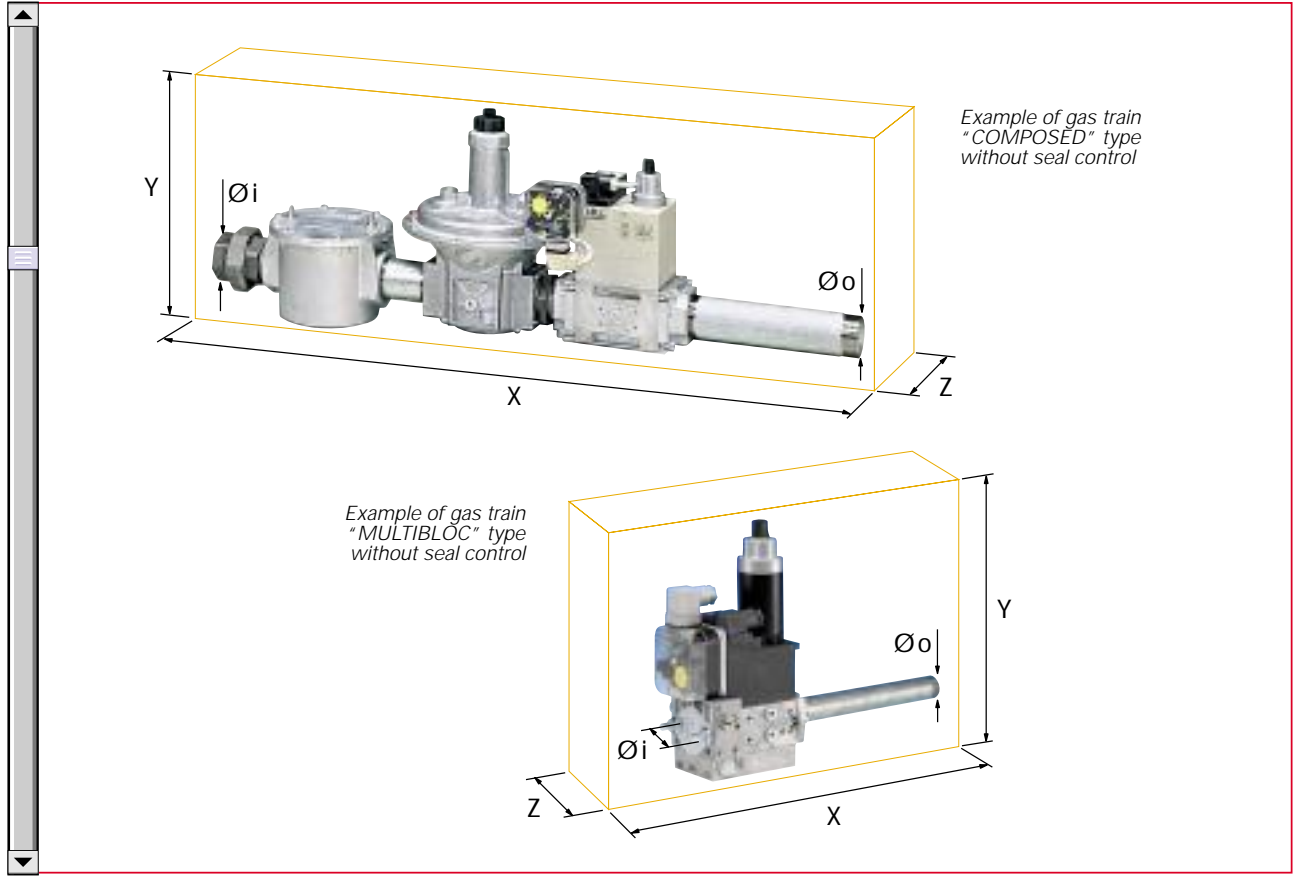

Gas trains are approved by standard EN 676 together with the burner.

The overall dimensions of the gas train depends on how they are constructed. The following table shows the maximum dimensions of the gas trains that can be fitted to GI/EMME burners, inlet and outlet diameters and seal control if fitted.

Please note that the seal control can be installed as an accessory, if not already installed on the gas train.

The maximum gas pressure of gas train "Multibloc" type is 300 mbar, and the one of the gas train "Composed" type is 500 mbar.

	Name	Code	Ø i	Ø o	X mm	Y mm	Z mm	SC
MULTIBLOC GAS TRAINS	MBD 420	3970181	2"	2"	523	300	100	-
	MBD 420 CT	3970182	2"	2"	523	300	227	Incorporated
	CB 50/1	3970146	2"	2"	986	328	250	-
COMPOSED GAS TRAINS	CB 50/1 CT	3970160	2"	2"	986	328	250	Incorporated
	CBF 65/1	3970147	DN 65	DN 65	874	356	285	-
	CBF 65/1 CT	3970161	DN 65	DN 65	874	356	285	Incorporated
	CBF 80/1	3970148	DN 80	DN 80	934	416	285	-
	CBF 80/1 CT	3970162	DN 80	DN 80	934	416	285	Incorporated
	CBF 100/1	3970149	DN 100	DN 100	1054	501	350	-
	CBF 100/1 CT	3970163	DN 100	DN 100	1054	501	350	Incorporated

When the diameter of the gas train is different from the set diameter of the burners, an adapter must be fitted between the gas train and the burner.
For further information see "Accessories" section.



► PRESSURE DROP DIAGRAM

The diagrams indicate the minimum pressure drop of the burners with the various gas trains that can be matched with them; at the value of these pressure drop add the combustion chamber pressure.

The value thus calculated represents the minimum required input pressure to the gas train.

NATURAL GAS

GI/EMME 1400

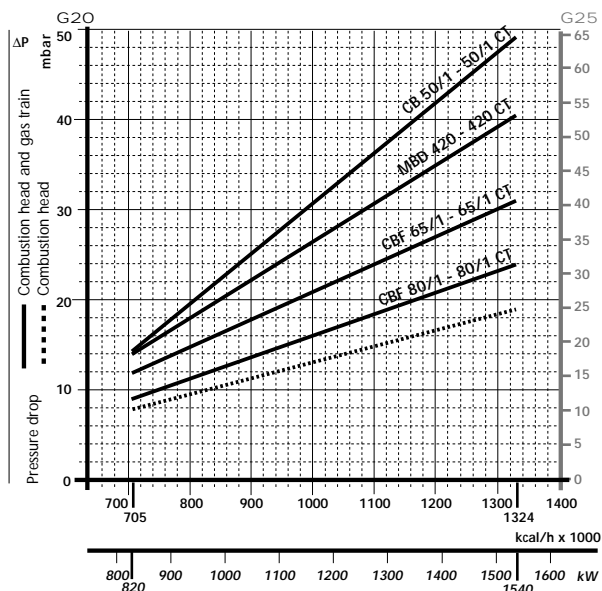

Gas train	Code	Adapter	Seal Control
MBD 420	3970181	-	Accessory
MBD 420 CT	3970182	-	Incorporated
CB 50/1	3970146	-	Accessory
CB 50/1 CT	3970160	-	Incorporated

LPG

GI/EMME 1400

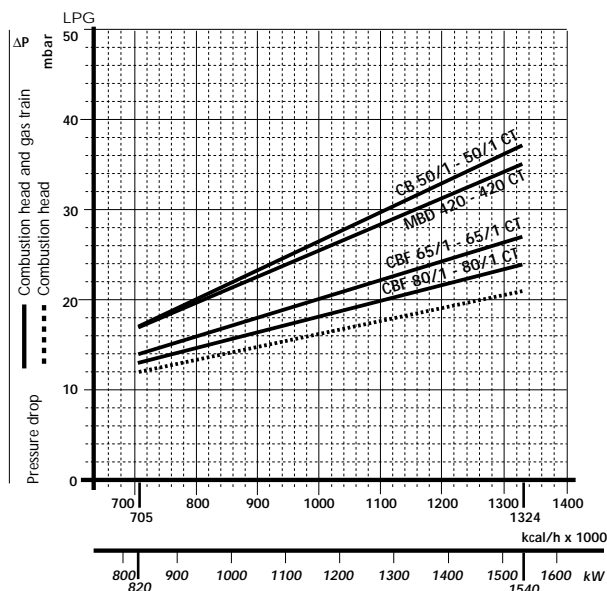

Gas train	Code	Adapter	Seal Control
CBF 65/1	3970147	3000825	Accessory
CBF 65/1 CT	3970161	3000825	Incorporated
CBF 80/1	3970148	3000826	Accessory
CBF 80/1 CT	3970162	3000826	Incorporated

GI/EMME 2000

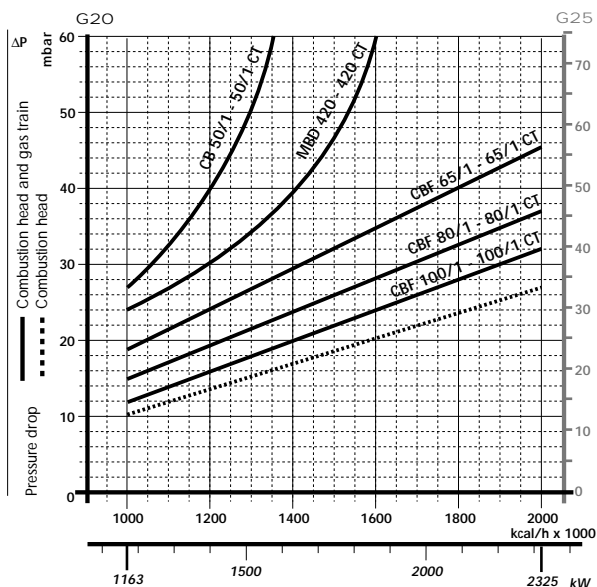

Gas train	Code	Adapter	Seal Control
MBD 420	3970181	-	Accessory
MBD 420 CT	3970182	-	Incorporated
CB 50/1	3970146	-	Accessory
CB 50/1 CT	3970160	-	Incorporated
CBF 65/1	3970147	3000825	Accessory

GI/EMME 2000

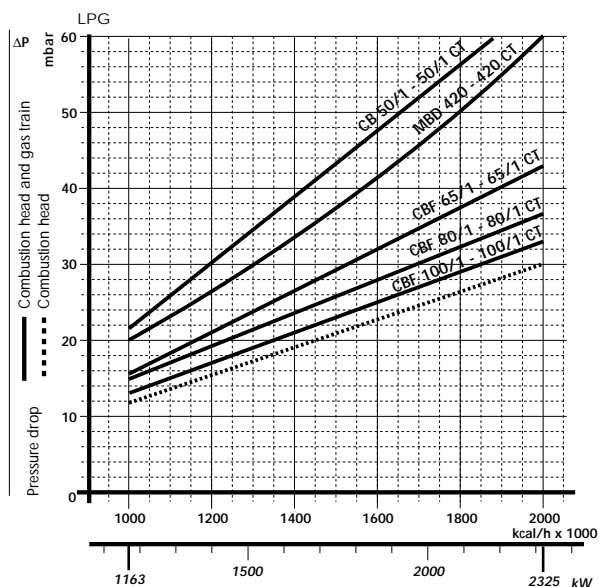

Gas train	Code	Adapter	Seal Control
CBF 65/1 CT	3970161	3000825	Incorporated
CBF 80/1	3970148	3000826	Accessory
CBF 80/1 CT	3970162	3000826	Incorporated
CBF 100/1	3970149	3010127	Accessory
CBF 100/1 CT	3970163	3010127	Incorporated



NATURAL GAS

LPG

GI/EMME 3000

GI/EMME 3000

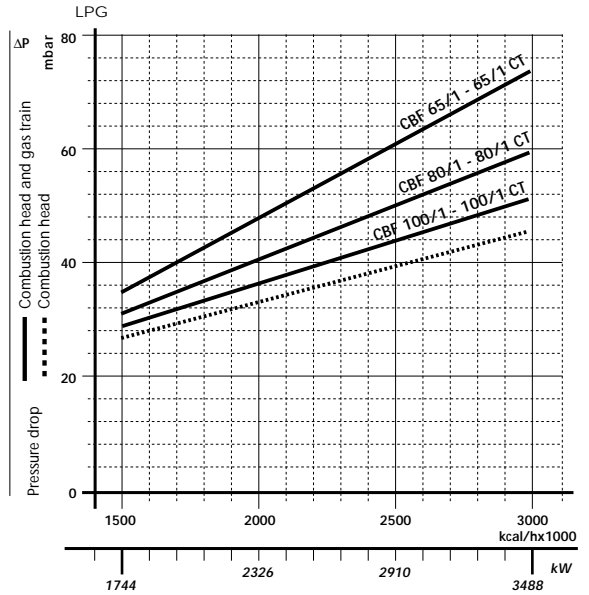
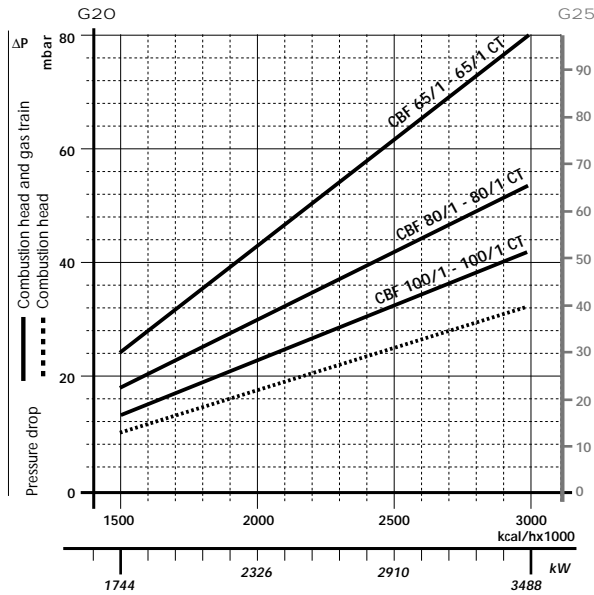

Gas train	Code	Adapter	Seal Control
CBF 65/1	3970147	3000831	Accessory
CBF 65/1 CT	3970161	3000831	Incorporated
CBF 80/1	3970148	3000832	Accessory

Gas train	Code	Adapter	Seal Control
CBF 80/1 CT	3970162	3000832	Incorporated
CBF 100/1	3970149	3010127	Accessory
CBF 100/1 CT	3970163	3010127	Incorporated

GI/EMME 4500

GI/EMME 4500

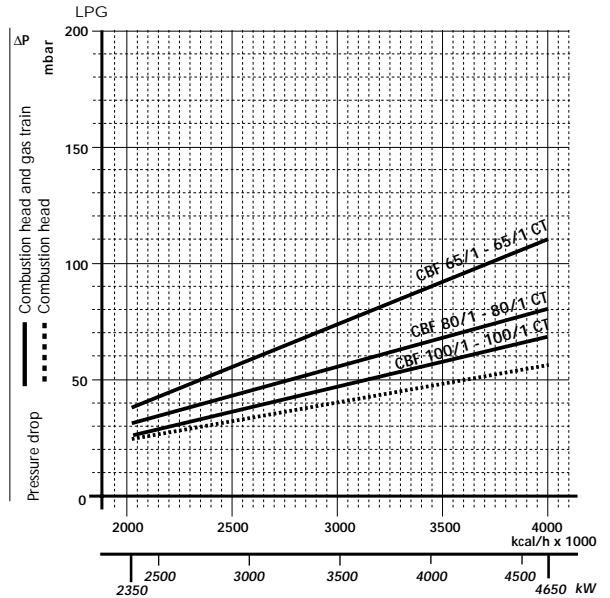
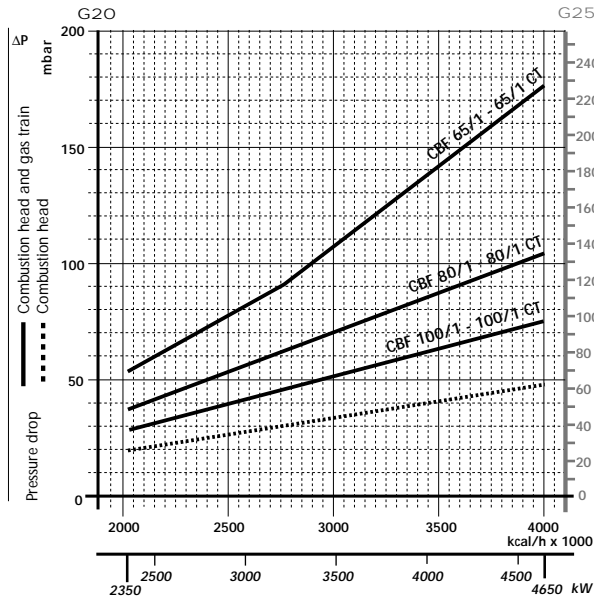

Gas train	Code	Adapter	Seal Control
CBF 65/1	3970147	3000831	Accessory
CBF 65/1 CT	3970161	3000831	Incorporated
CBF 80/1	3970148	3000832	Accessory

Gas train	Code	Adapter	Seal Control
CBF 80/1 CT	3970162	3000832	Incorporated
CBF 100/1	3970149	3010127	Accessory
CBF 100/1 CT	3970163	3010127	Incorporated

note Please contact the Riello Burner Technical Office for different pressure levels from those above indicated.





SELECTING THE FUEL SUPPLY LINES

The following diagram enables pressure drop in a pre-existing gas line to be calculated and to select the correct gas train.

The diagram can also be used to select a new gas line when fuel output and pipe length are known. The pipe diameter is selected on the basis of the desired pressure drop. The diagram uses methane gas as reference; if another gas is used, conversion coefficient and a simple formula (on the diagram) transform the gas output to a methane equivalent (refer to figure A). Please note that the gas train dimensions must take into account the back pressure of the combustion chamber during operations.

Control of the pressure drop in an existing gas line or selecting a new gas supply line. The methane output equivalent is determined by the formula fig. A on the diagram and the conversion coefficient.

Once the equivalent output has been determined on the delivery scale (\dot{V}), shown at the top of the diagram, move vertically downwards until you cross the line that represents the pipe diameter; at this point, move horizontally to the left until you meet the line that represents the pipe length.

Once this point is established you can verify, by moving vertically downwards, the pipe pressure drop on the bottom scale below (mbar).

By subtracting this value from the pressure measured on the gas meter, the correct pressure value will be found for the choice of gas train.

Example: - gas used G25
 - gas output 9.51 mc/h
 - pressure at the gas meter 20 mbar
 - gas line length 15 m
 - conversion coefficient 0.62 (see figure A)

- equivalent methane output $\dot{V} = \left[\frac{9.51}{0.62} \right] = 15.34 \text{ mc/h}$

- once the value of 15.34 has been identified on the output scale (\dot{V}), moving vertically downwards you cross the line that represents 1" 1/4 (the chosen diameter for the piping);

- from this point, move horizontally to the left until you meet the line that represents the length of 15 m of the piping;

- move vertically downwards to determine a value of 1.4 mbar in the pressure drop bottom scale;

- subtract the determined pressure drop from the meter pressure, the correct pressure level will be found for the choice of gas train;

- correct pressure = (20-1.4) = 18.6 mbar

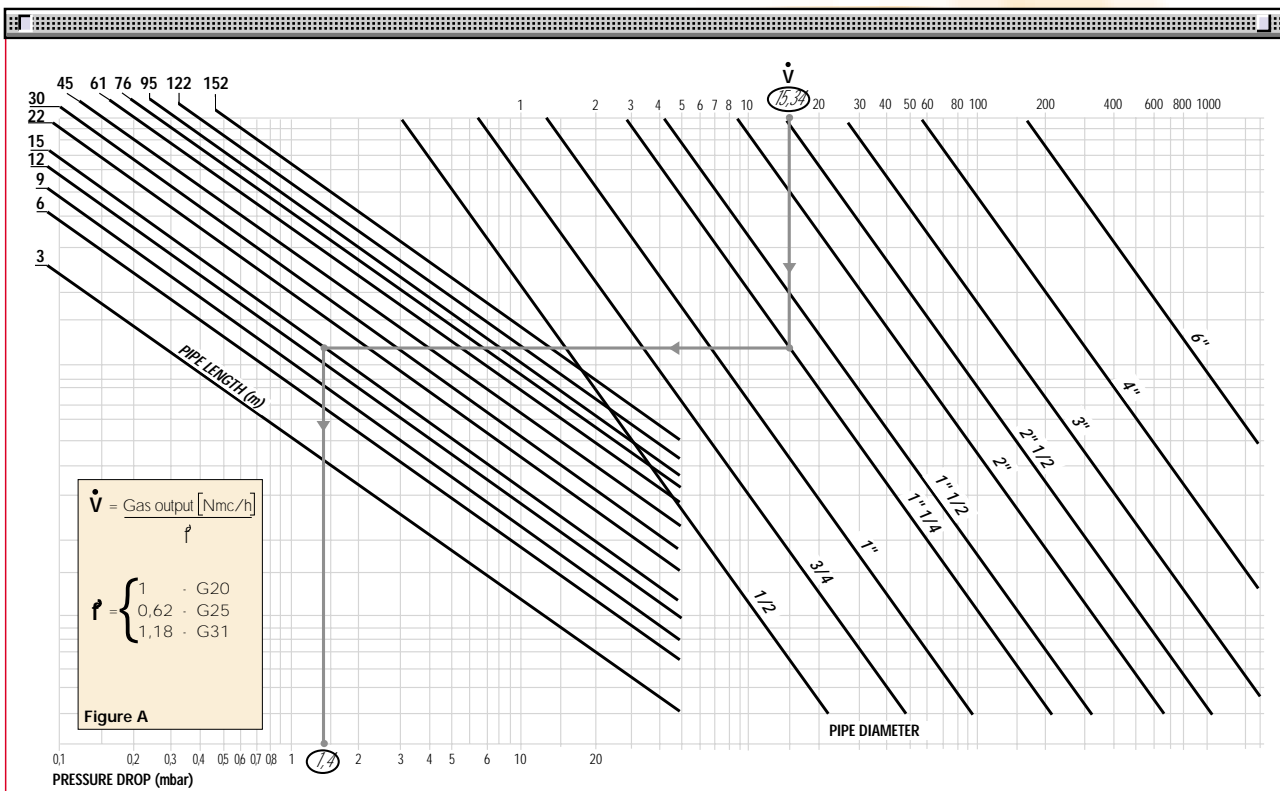



▶ HYDRAULIC CIRCUIT

The hydraulic circuit of the GI/EMME series of burners is characterised by a fuel pump with an independent motor.

The burners are fitted with two valves (a safety valve and an operation valve) and an oil filter along the oil line from the pump to the nozzle.

A pressure regulator on the return circuit from the nozzle enables the quantity of fuel burnt to be varied. Two safety valves on the return circuit avoid oil leakage from the nozzle when the burner is in stand-by and pre-purge phase.

The models are fitted with a maximum pressure switch on the oil return circuit, and a minimum oil pressure switch on the oil line from the pump to the nozzle.



Example of oil circuit in GI/EMME series of burners

EN 267 > 100 kg/h

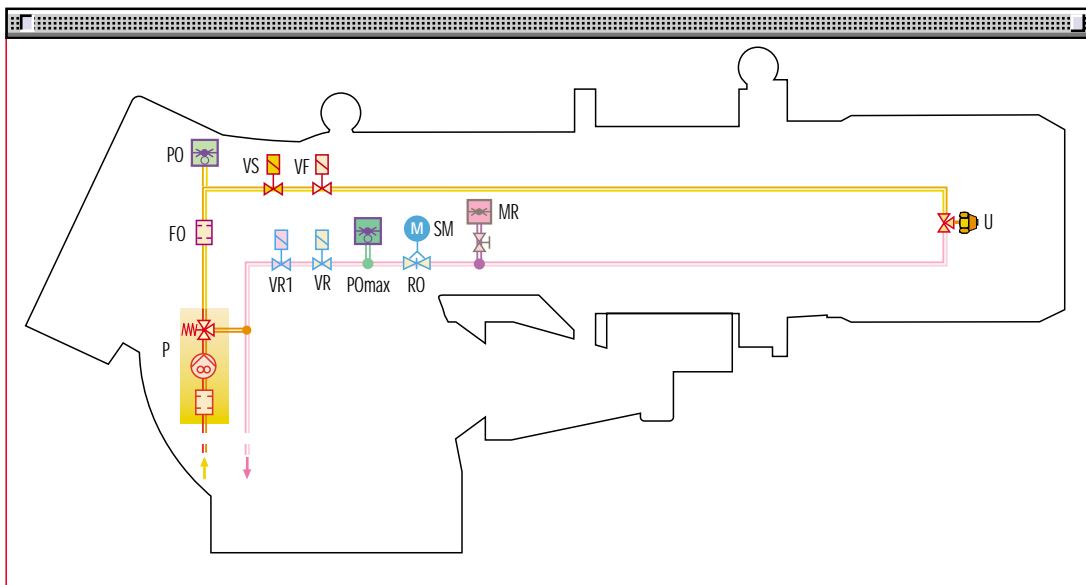

P	Pump with filter and pressure regulator on the output circuit
FO	Oil filter
VS	Safety valve on the output circuit
VF	Working valve on the output circuit
U	Nozzle
MR	Pressure gauge on the return circuit
SM	Servomotor
RO	Pressure regulator on the return circuit
PO max	Max. oil pressure switch on the return circuit
VR	1st safety valve on the return circuit
VR1	2nd safety valve on the return circuit
PO	Min. oil pressure switch on the output circuit



SELECTING THE FUEL SUPPLY LINES

The fuel feed must be completed with the safety devices required by the local norms.

The table shows the choice of piping diameter for the various burners, depending on the difference in height between the burner and the tank and their distance.

MAXIMUM EQUIVALENT LENGTH FOR THE PIPING L[m]								
Model	▼ GI/EMME 1400		▼ GI/EMME 2000		▼ GI/EMME 3000		▼ GI/EMME 4500	
Piping diameter	14mm	16mm	16mm	18mm	G 1/2"	G 3/4"	G 3/4"	G 1"
+H, -H (m)	Lmax (m)	Lmax (m)	Lmax (m)	Lmax (m)	Lmax (m)	Lmax (m)	Lmax (m)	Lmax (m)
+2,0	55	70	40	60	25	85	55	130
+1,5	45	65	35	55	23	80	50	120
+1,0	40	60	30	50	20	70	45	110
+0,5	35	50	25	45	18	65	40	100
0	30	45	20	40	15	60	35	90
-0,5	25	40	18	35	12	50	30	80
-1,0	20	35	15	30	10	45	25	70
-1,5	15	30	13	25	8	35	20	60
-2,0	10	25	10	20	5	30	15	45
-3,0	5	15	5	10	3	15	10	25

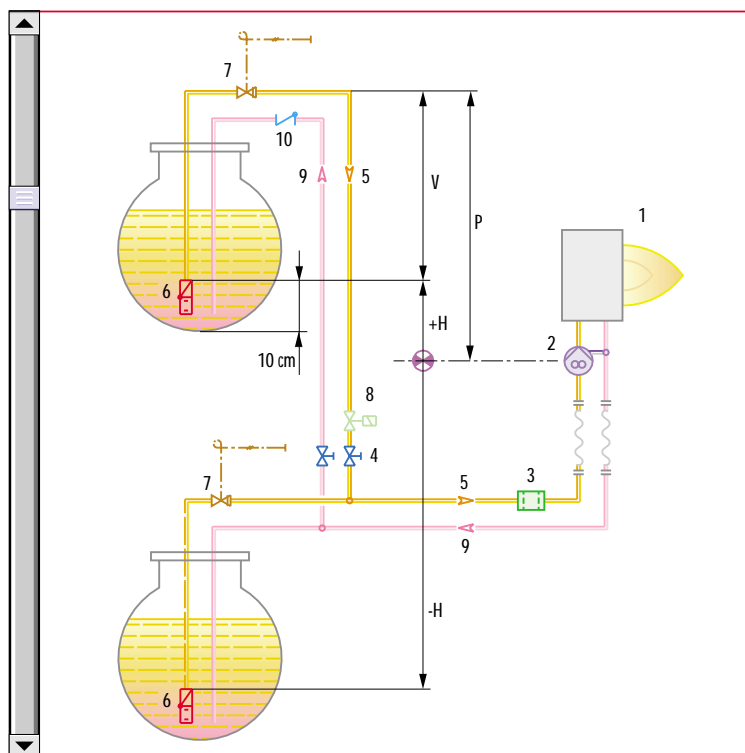

H	Difference in height pump-foot valve
Ø	Internal pipe diameter
P	Max. height 10 m
V	Height 4 m
1	Burner
2	Burner pump
3	Filter
4	Manual shut off valve
5	Suction pipework
6	Bottom valve
7	Remote controlled rapid manual shut off valve (compulsory in Italy)
8	Type approved shut off solenoid valve (compulsory in Italy)
9	Return pipework
10	Check valve

note With ring distribution oil systems, the feasible drawings and dimensioning are the responsibility of specialised engineering studios, who must check compatibility with the requirements and features of each single installation.

VENTILATION

The ventilation circuit comes with a forward blades centrifugal fan, which guarantees high pressure levels at the required air deliveries and permits installation flexibility.

In spite of the remarkable output power and of the very high pressure performance, GI/EMME models are extremely compact.

Sound proofing boxes help to reduce the noise level.

A variable profile cam connects fuel and air setting, ensuring fuel efficiency at all firing rates.

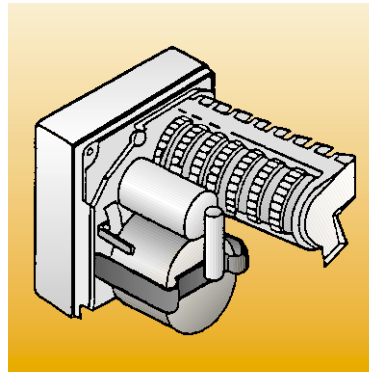

Example of servomotor mounted on GI/EMME series of burner



COMBUSTION HEAD

Two different combustion head length can be selected for the various models of GI/EMME series of burners.

The choice depends on the thickness of the front panel and type of boiler. Correct head penetration into the combustion chamber depends on the type of heat generator.

These burners are equipped with a variable geometry combustion head. This enables optimum combustion performance throughout the working field, ensuring peak combustion efficiency thus saving on fuel consumption.

The following diagram shows the flame dimensions in relation to the burner output. The lengths and diameter shown in the diagram below should be employed for a preliminary check: if the combustion chamber dimensions are different from the values in the diagram, further tests need to be done.



Example of GI/EMME combustion head

Flame dimensions

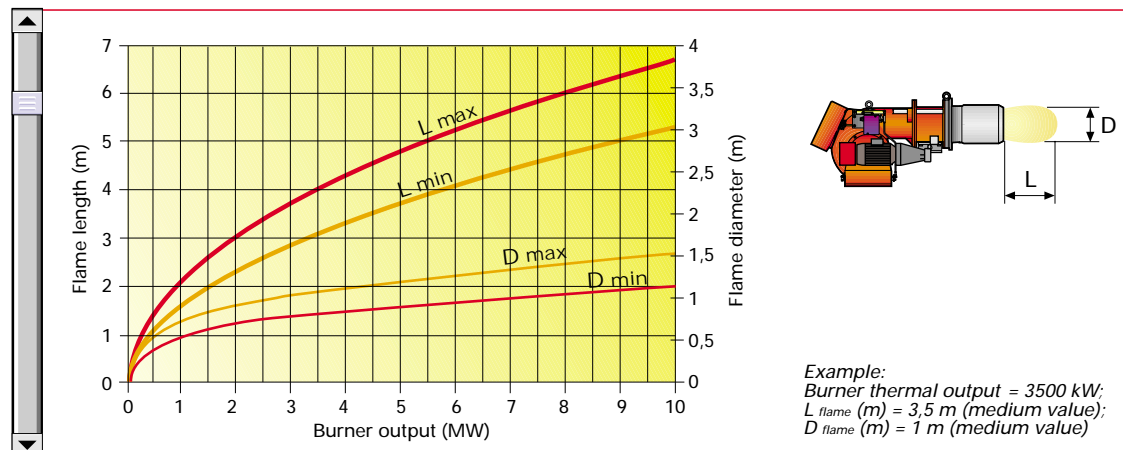



ADJUSTMENT

BURNER OPERATION MODE

The GI/EMME series of burners can be "two stage progressive" or "modulating".

During "two stage progressive" operation, the burner gradually adapts the output to the required level, by varying between two pre-set levels (see figure A).

During "modulating" operation, normally required in steam generators, in superheated water boilers or thermal oil boilers, a specific regulator and probes are required. These are supplied as accessories that must be ordered separately. The burner can work for long periods at intermediate output levels (see figure B).

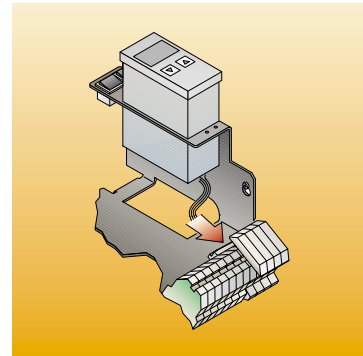

Example of a regulator

"Two stage progressive" operation

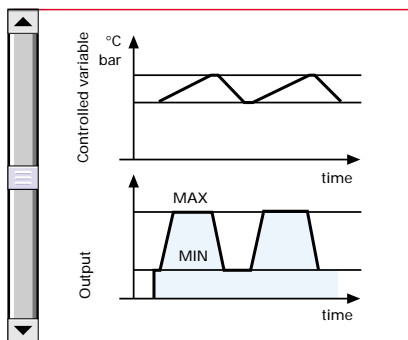

Figure A

"Modulating" operation

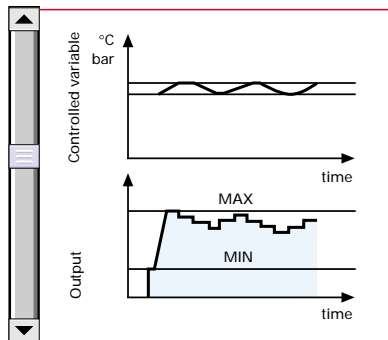
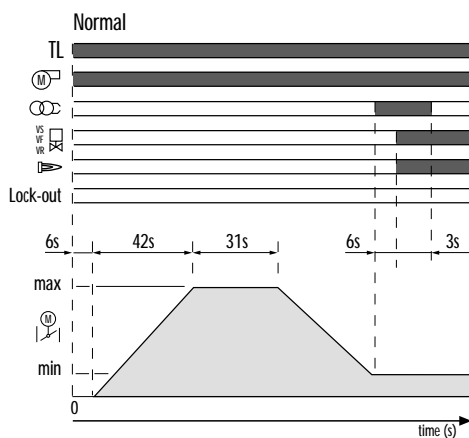

Figure B

START UP CYCLE



- 0" The burner begins the start-up cycle: the motor starts turning.
- 6" -48" The servomotor opens the air damper at the maximum position.
- 48" -79" Pre-purge phase with air damper open.
- 79" -n" The servomotor takes the air damper to the ignition position.
- n" Ignition transformer turns on.
- 6" after Oil solenoid valves open and flame detection with P.E. cell is activated.
- 3" After a safety time, the ignition transformer turns off if there is the flame, otherwise lock-out happens.

WIRING DIAGRAMS



Electrical connections must be made by qualified and skilled personnel, according to the local norms.

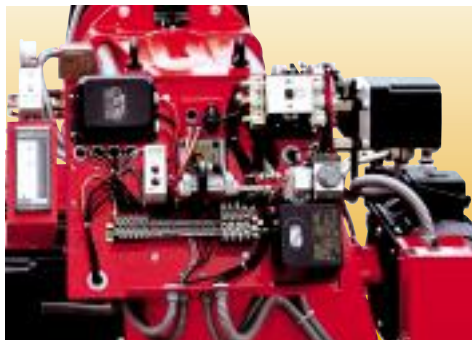

Example of the terminal board for the electrical connections for GI/EMME burner models

“ TWO STAGE PROGRESSIVE ” OPERATION

GI/EMME 1400 - 2000 - 3000 (direct start-up) Without seal control

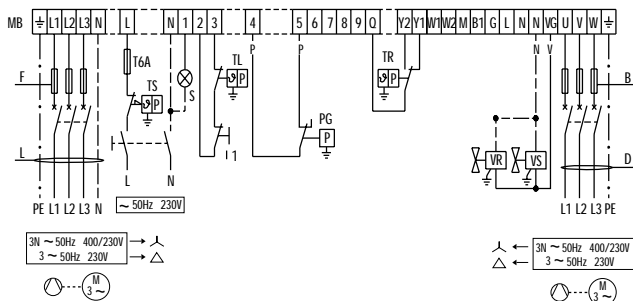

- I1 - Burner manual stop switch (optional)
- PG - Min. gas pressure switch
- S - Remote lock-out signal
- TR - High-low mode load remote control system
- TL - Load limit remote control system
- TS - Safety load control system
- VR - Regulating gas valve
- VS - Safety gas valve
- MB - Burner terminal board
- T6A - 6A Fuse
- F, B - Fuse
- L, H, D - Lead section

GI/EMME 2000 - 3000 - 4500 (direct start-up) With seal control

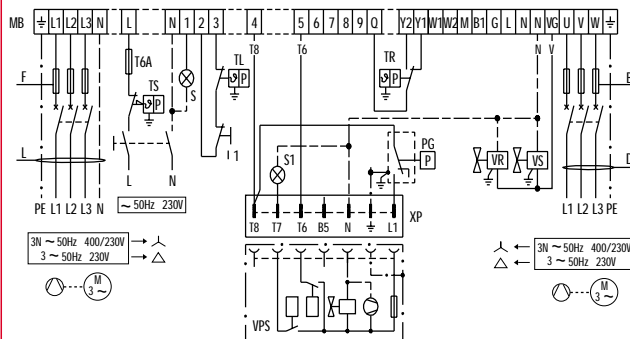

- I1 - Burner manual stop switch (optional)
- XP - Plug for seal control device
- PG - Min gas pressure switch
- S - Remote lock-out signal
- S1 - Remote lock-out signal of seal control device
- TR - High-low mode load remote control system
- TL - Load limit remote control system
- TS - Safety load control system
- VR - Regulating gas valve
- VS - Safety gas valve
- MB - Burner terminal board
- VPS - Seal control device
- T6A - 6A Fuse
- F, B - Fuse
- L, H, D - Lead section



GI/EMME 1400 - 2000 - 3000 (star delta start-up) Without seal control

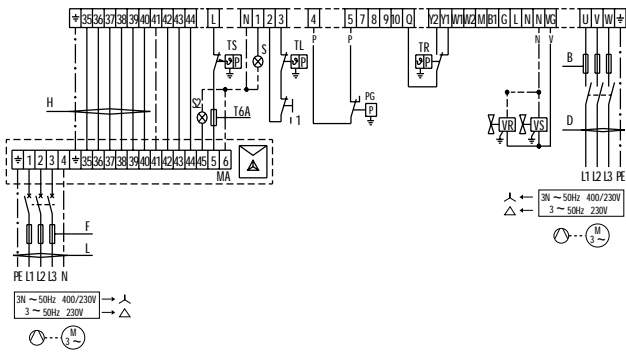

- I1 - Burner manual stop switch (optional)
- PG - Min gas pressure switch
- S - Remote lock-out signal
- TR - High-low mode load remote control system
- TL - Load limit remote control system
- TS - Safety load control system
- VR - Regulating gas valve
- VS - Safety gas valve
- MB - Burner terminal board
- MA - Star delta starter terminal board
- S2 - Fan lock-out signal
- T6A - 6A Fuse
- F, B - Fuse
- L, H, D - Lead section

GI/EMME 2000 - 3000 - 4500 (star delta start-up) With seal control

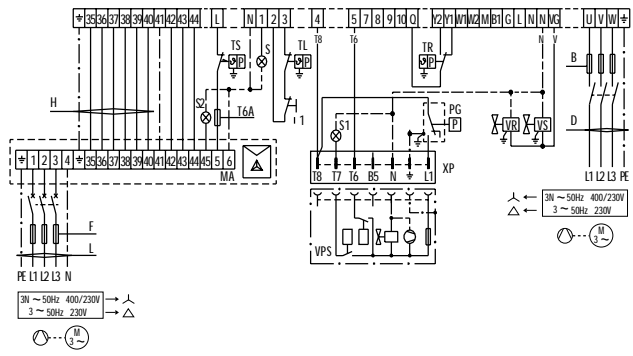

- I1 - Burner manual stop switch (optional)
- XP - Plug for seal control device
- PG - Min gas pressure switch
- S - Remote lock-out signal
- S1 - Remote lock-out signal of seal control device
- TR - High-low mode load remote control system
- TL - Load limit remote control system
- TS - Safety load control system
- VR - Regulating gas valve
- VS - Safety gas valve
- MB - Burner terminal board
- VPS - Seal control device
- MA - Star delta starter terminal board
- S2 - Fan lock-out signal
- T6A - 6A Fuse
- F, B - Fuse
- L, H, D - Lead section

► "MODULATING" OPERATION - TEMPERATURE PROBE

GI/EMME 1400 - 2000 - 3000 (direct start-up)

- I1 - Burner manual stop switch (optional)
- XP - Plug for seal control device
- PG - Min gas pressure switch
- S - Remote lock-out signal
- S1 - Remote lock-out signal of seal control device
- TL - Load limit remote control system
- TS - Safety load control system
- VR - Regulating gas valve
- VS - Safety gas valve
- MB - Burner terminal board
- VPS - Seal control device
- RWF40 - Regulator (fitted to the burner)
- BT - Temperature probe
- T6A - 6A Fuse
- F, B - Fuse
- L, H, D - Lead section

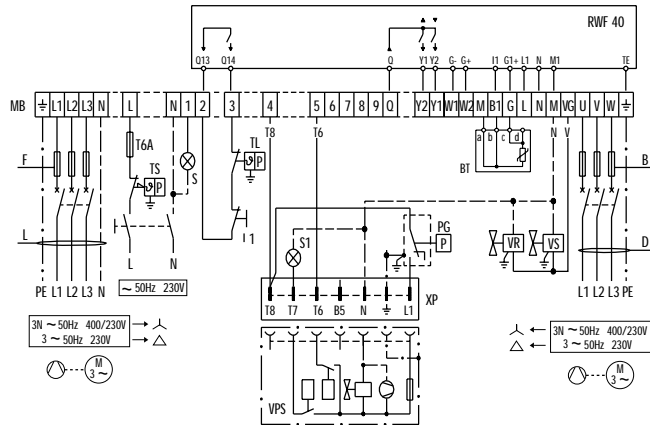

GI/EMME 2000 - 3000 - 4500 (star delta start-up)

- I1 - Burner manual stop switch (optional)
- XP - Plug for seal control device
- PG - Min gas pressure switch
- S - Remote lock-out signal
- S1 - Remote lock-out signal of seal control device
- TL - Load limit remote control system
- TS - Safety load control system
- VR - Regulating gas valve
- VS - Safety gas valve
- MB - Burner terminal board
- VPS - Seal control device
- MA - Star delta starter terminal board
- S2 - Fan lock-out signal
- RWF40 - Regulator (fitted to the burner)
- BT - Temperature probe
- T6A - 6A Fuse
- F, B - Fuse
- L, H, D - Lead section

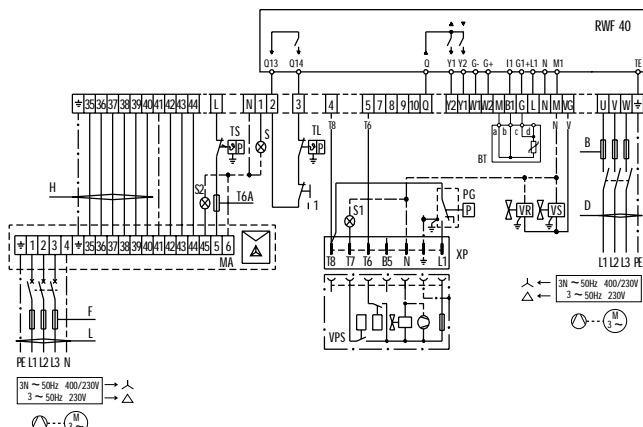



► “MODULATING” OPERATION - PRESSURE PROBE

GI/EMME 1400 - 2000 - 3000 (direct start-up)

- I1 - Burner manual stop switch (optional)
- XP - Plug for seal control device
- PG - Min gas pressure switch
- S - Remote lock-out signal
- S1 - Remote lock-out signal of seal control device
- TL - Load limit remote control system
- TS - Safety load control system
- VR - Regulating gas valve
- VS - Safety gas valve
- MB - Burner terminal board
- VPS - Seal control device
- RWF40 - Regulator (fitted to the burner)
- BT - Pressure probe
- T6A - 6A Fuse
- F,B - Fuse
- L,H,D - Lead section

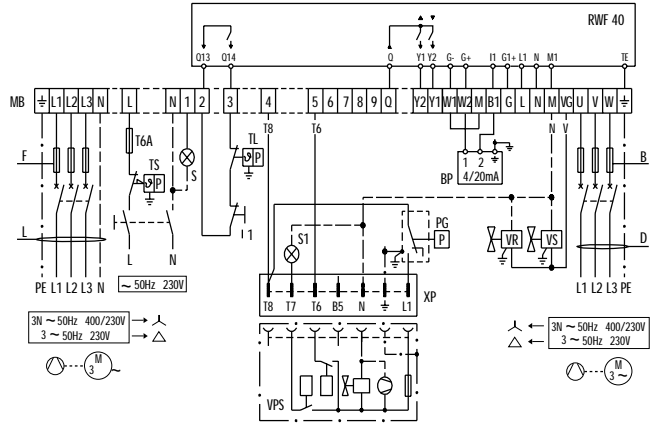

GI/EMME 2000 - 3000 - 4500 (star delta start-up)

- I1 - Burner manual stop switch (optional)
- XP - Plug for seal control device
- PG - Min gas pressure switch
- S - Remote lock-out signal
- S1 - Remote lock-out signal of seal control device
- TL - Load limit remote control system
- TS - Safety load control system
- VR - Regulating gas valve
- VS - Safety gas valve
- MB - Burner terminal board
- VPS - Seal control device
- RWF40 - Regulator (fitted to the burner)
- BT - Pressure probe
- MA - Star delta starter terminal board
- S2 - Fan lock-out signal
- T6A - 6A Fuse
- F,B - Fuse
- L,H,D - Lead section

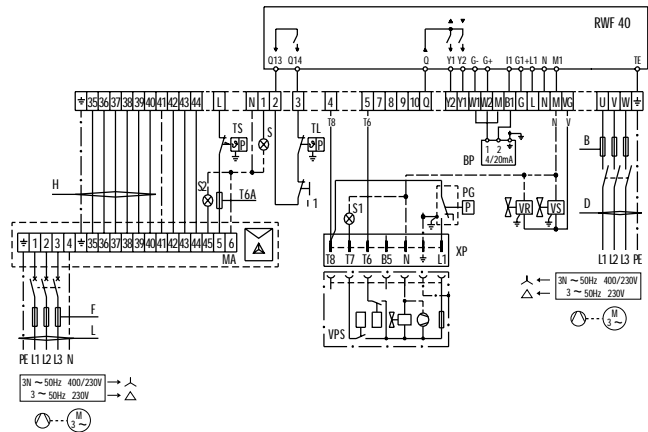

The following table shows the supply lead sections and the type of fuse to be used.

Model	Direct start-up						Star delta start-up					
	GI/EMME 1400		GI/EMME 2000		GI/EMME 3000		GI/EMME 2000		GI/EMME 3000		GI/EMME 4500	
	230 V	400 V	230 V	400 V	230 V	400 V	230 V	400 V	230 V	400 V	230 V	400 V
F A	20	16	25	20	40	32	25	20	40	32	63	40
B A	6	4	6	4	10	6	6	4	10	6	10	6
L mm ²	2,5	2,5	2,5	2,5	6	4	2,5	2,5	2,5	2,5	6	4
D mm ²	1,5	1,5	1,5	1,5	2,5	1,5	1,5	1,5	1,5	1,5	2,5	1,5
H mm ²	-	-	-	-	-	-	1,5	1,5	2,5	2,5	4	2,5



EMISSIONS

NO_x EMISSIONS

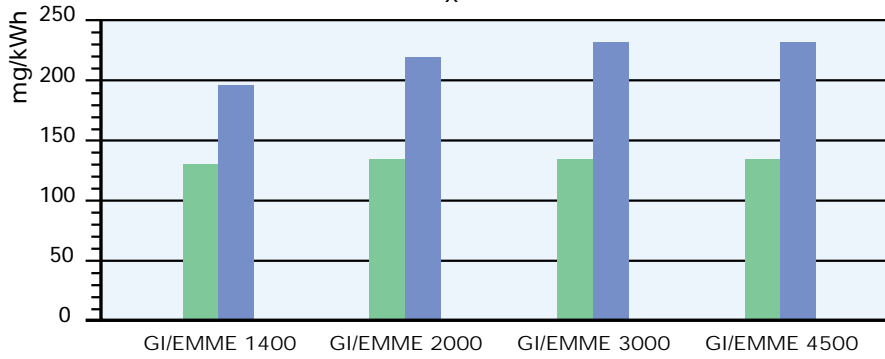

CO EMISSIONS

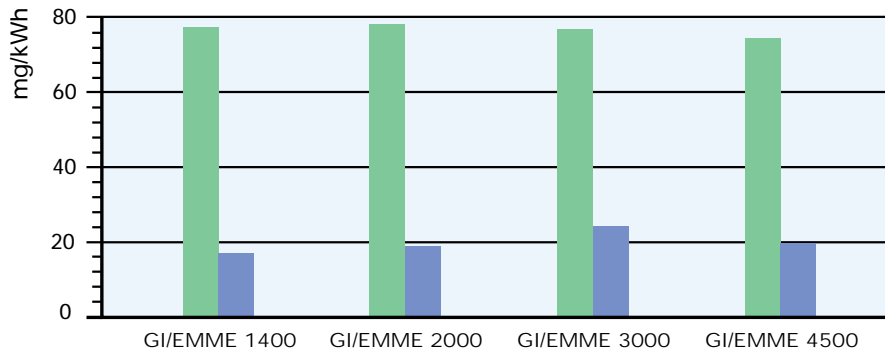

NOISE EMISSIONS

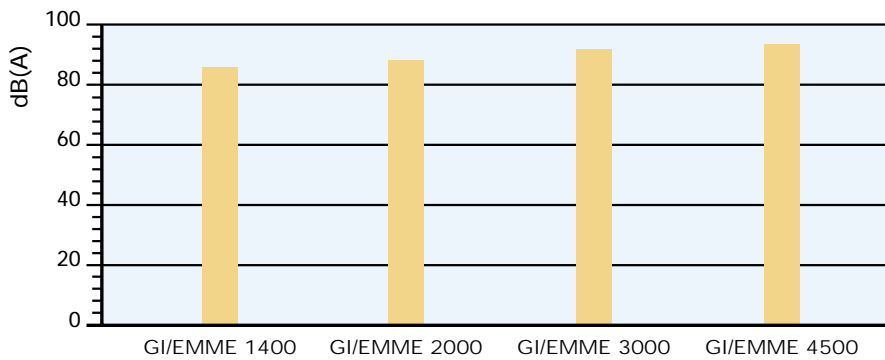

Gas working
Light oil working

The emission data has been measured in the various models at maximum output, according to EN 676 and EN 267 standard.

OVERALL DIMENSIONS (mm)



BURNER

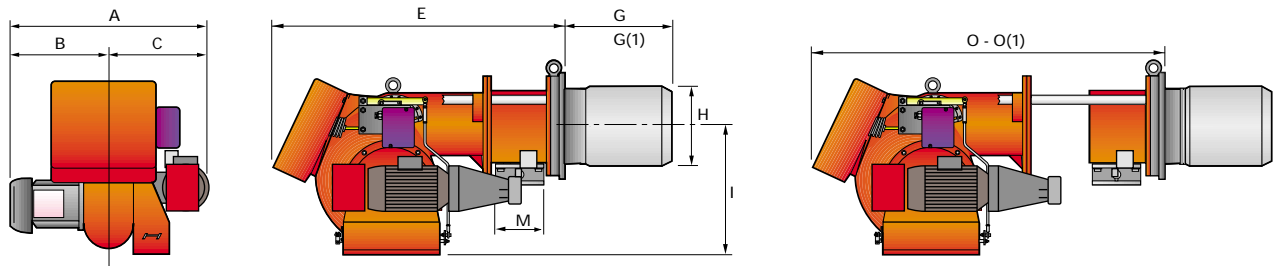

Model	A	B	C	E	G	G(1)	H	M	I	O	O(1)
▶ GI/EMME 1400	858	376	482	1090	385	495	250	2"	467	1407	1585
▶ GI/EMME 2000	878	396	482	1090	385	495	260	DN 80	467	1407	1585
▶ GI/EMME 3000	985	447	538	1320	476	606	336	DN 80	525	1796	2000
▶ GI/EMME 4500	1046	508	538	1320	476	606	336	DN 80	525	1796	1926

(1) Length with extended combustion head.

BURNER - BOILER MOUNTING FLANGE

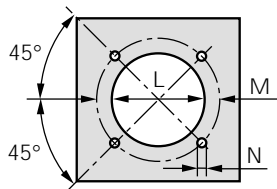

Model	L	M	N
▶ GI/EMME 1400	255	260	M 16
▶ GI/EMME 2000	265	260	M 16
▶ GI/EMME 3000	340	310	M 20
▶ GI/EMME 4500	340	310	M 20

PACKAGING

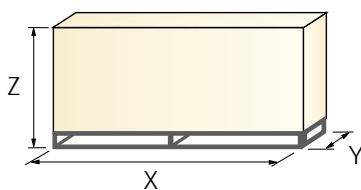

Model	X	Y	Z	kg
▶ GI/EMME 1400	1670	1010	780	190
▶ GI/EMME 2000	1670	1010	780	200
▶ GI/EMME 3000	2000	1160	870	280
▶ GI/EMME 4500	2000	1160	870	280



INSTALLATION DESCRIPTION

Installation, start up and maintenance must be carried out by qualified and skilled personnel. All operations must be performed in accordance with the technical handbook supplied with the burner.

BURNER SETTING

- ▶ All the burners have slide bars, for easier installation and maintenance.
- ▶ After drilling the boilerplate, using the supplied gasket as a template, dismantle the blast tube from the burner and fix it to the boiler.
- ▶ Adjust the combustion head.
- ▶ Fit the gas train choosing this on the basis of the maximum boiler output and following the diagrams included in the burner instruction handbook
- ▶ Refit the burner casing to the slide bars.
- ▶ Install the nozzle choosing this on the basis of the maximum boiler output and following the diagrams included in the burner instruction handbook.
- ▶ Check the position of the electrodes.
- ▶ Close the burner, sliding it up to the flange, keeping it slightly raised to avoid the flame stability disk rubbing against the blast tube.

ELECTRICAL AND HYDRAULIC CONNECTIONS AND START UP

- ▶ The burners are supplied for connection to two pipes fuel supply system.
- ▶ Connect the ends of the flexible pipes to the suction and return pipework using the supplied nipples.
- ▶ Make the electrical connections to the burner following the wiring diagrams included in the instruction handbook.
- ▶ Prime the pump by turning the motor (after checking rotation direction if it is a three phase motor).
- ▶ Adjust the gas train for first start
- ▶ On start up, check:
 - ▶ Pressure pump and valve unit regulator (to max. and min.)
 - ▶ Gas pressure at the combustion head (to max. and min. output)
 - ▶ Combustion quality, in terms of unburned substances and excess air.

BURNER ACCESSORIES



Nozzles

The nozzles must be ordered separately. The following table shows the features and codes on the basis of the maximum required fuel output.

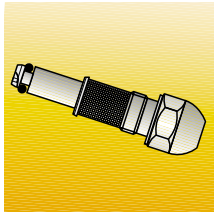

Nozzles type B3 - SA 45°		
Burner	Rated delivery (*) (kg/h)	Nozzle code
GI/EMME 1400	70	3009713
GI/EMME 1400	80	3009715
GI/EMME 1400	90	3009717
GI/EMME 1400 - 2000	100	3009720
GI/EMME 1400 - 2000	125	3009723
GI/EMME 2000 - 3000	150	3009726
GI/EMME 2000 - 3000	175	3009729
GI/EMME 2000 - 3000 - 4500	200	3009732
GI/EMME 3000 - 4500	225	3009735
GI/EMME 3000 - 4500	250	3009738
GI/EMME 3000 - 4500	275	3009741
GI/EMME 3000 - 4500	300	3009744
GI/EMME 4500	325	3009747
GI/EMME 4500	350	3009750
GI/EMME 4500	375	3009753
GI/EMME 4500	400	3009756

(*) Nozzle rated delivery is referred to atomised pressure.

Spacer kit

If burner head penetration into the combustion chamber needs reducing, varying thickness spacers are available, as given in the following list:

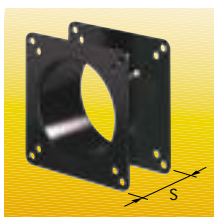

Spacer kit		
Burner	Spacer thickness S (mm)	Kit code
GI/EMME 1400 - 2000	110	3000722
GI/EMME 3000 - 4500	130	3000751

Sound proofing box

If noise emission needs reducing even further, sound-proofing boxes are available, as given in the following table:



Sound proofing box		
Burner	Box type	Box code
GI/EMME 1400 - 2000	C7	3010048
GI/EMME 3000 - 4500	C8	3010049

Accessories for modulating operation

To obtain modulating setting, the GI/EMME series of burners requires a regulator with three point outlet controls. The relative temperature or pressure probes fitted to the regulator must be chosen on the basis of the application.

The following table lists the accessories for modulating setting with their application range.



Burner	Regulator type	Code
GI/EMME 1400 - 2000 - 3000 - 4500	RWF 40	3010211



Probe type	Range (°C) (bar)	Probe code
Temperature PT 100	-100 ÷ 500°C	3010110
Pressure 4 ÷ 20 mA	0 ÷ 2,5 bar	3010213
Pressure 4 ÷ 20 mA	0 ÷ 16 bar	3010214

Depending on the servomotor fitted to the burner, a three-pole potentiometer (1000 Ω) can be installed to check the position of the servomotor. The KITS available for the various burners are listed below.



Burner	Potentiometer kit code
GI/EMME 1400 - 2000 - 3000 - 4500	3010021

LPG kit

For burning LPG gas, a special kit is available to be fitted to the combustion head on the burner, as given in the following table:

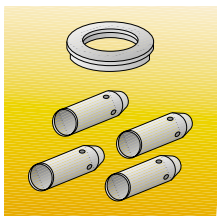

LPG kit		
Burner	Kit code for standard head	Kit code for extended head
GI/EMME 1400 - 2000	3010063	3010063

GAS TRAIN ACCESSORIES



Adapters

When the diameter of the gas train is different from the set diameter of the burners, an adapter must be fitted between the gas train and the burner. The following table lists the adapters for various burners.

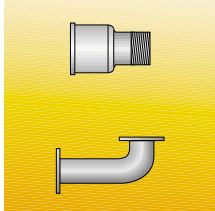

Adapters			
Burner	Gas train	Dimensions	Adapter code
GI/EMME 1400	CBF 65/1	DN 65 2" 1/2 1" 1/2 2"	3000825
	CBF 80/1	DN 80 2" 1/2 2"	3000826
GI/EMME 2000	MBD 420 CB 50/1	DN 80 DN 65 2" 1/2 2"	3010128
	CBF 65/1	DN 65 DN 80	3000831
	CBF 80/1	DN 80 DN 80	3000832
	CBF 100/1	DN 100 DN 80	3010127
GI/EMME 3000	CBF 65/1	DN 65 DN 80	3000831
	CBF 80/1	DN 80 DN 80	3000832
	CBF 100/1	DN 100 DN 80	3010127
GI/EMME 4500	CBF 65/1	DN 65 DN 80	3000831
	CBF 80/1	DN 80 DN 80	3000832
	CBF 100/1	DN 100 DN 80	3010127

Stabiliser spring

Accessory springs are available to vary the pressure range of the gas train stabilisers. The following table shows these accessories with their application range.

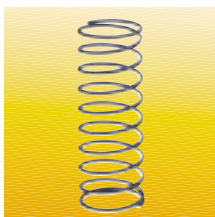

Stabiliser spring		
Gas train	Spring	Spring code
CBF 65/1 - CBF 80/1	Red from 25 to 55 mbar	3010133
CBF 100/1	Red from 25 to 55 mbar	3010134
CBF 65/1 - CBF 80/1	Black from 60 to 110 mbar	3010135
CBF 100/1	Black from 60 to 110 mbar	3010136
CBF 65/1 - CBF 80/1	Pink from 90 to 150 mbar	3090456
CBF 100/1	Pink from 90 to 150 mbar	3090489



Seal control kit

To test the valve seals on the gas train, a special "seal control kit" is available. The valve seal control device is compulsory (EN 676) on gas trains to burners with a maximum output over 1200 kW. The seal control is type VPS 504.



Seal control kit		
Burner	Gas train	Kit code
GI/EMME 1400	MBD 420 - CB 50/1 - CBF 65/1 - CBF 80/1	3010125
GI/EMME 2000	MBD 420 - CB 50/1 - CBF 65/1 - CBF 80/1- CBF 100/1	3010125
GI/EMME 3000	CBF 65/1 - CBF 80/1- CBF 100/1	3010125
GI/EMME 4500	CBF 65/1 - CBF 80/1- CBF 100/1	3010125



SPECIFICATION



A specific index guides your choice of burner from the various models available in the GI/EMME series. Below is a clear and detailed specification description of the product.

DESIGNATION OF SERIES

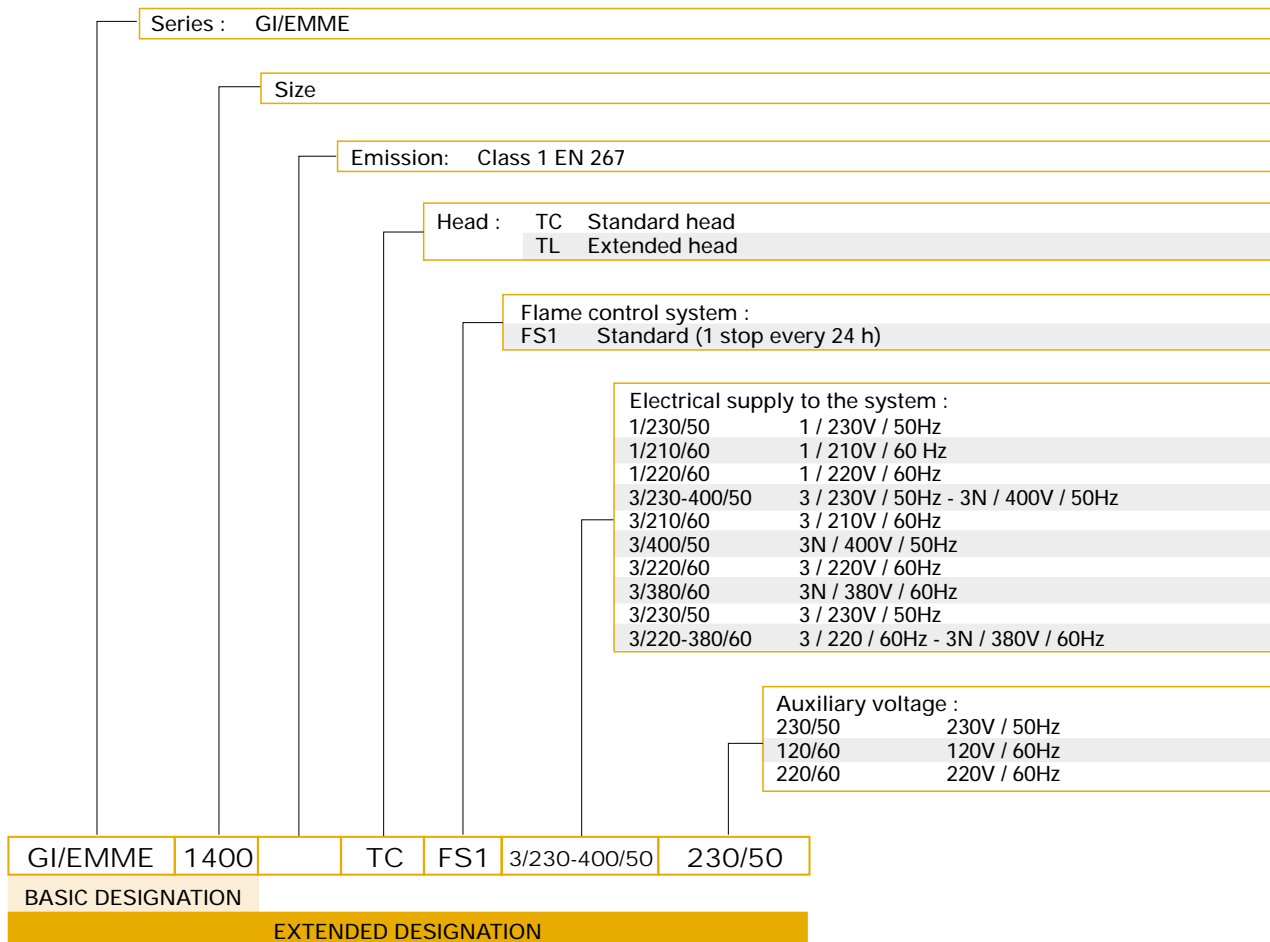



▶ AVAILABLE BURNER MODELS

GI/EMME 1400 TC FS1 3/220-380/60 220/60	GI/EMME 3000 TC FS1 3/400/50 230/50
GI/EMME 1400 TC FS1 3/230-400/50 230/50	GI/EMME 3000 TL FS1 3/220-380/60 220/60
GI/EMME 1400 TL FS1 3/220-380/60 220/60	GI/EMME 3000 TL FS1 3/230-400/50 230/50
GI/EMME 1400 TL FS1 3/230-400/50 230/50	GI/EMME 3000 TL FS1 3/400/50 230/50
GI/EMME 2000 TC FS1 3/220-380/60 220/60	GI/EMME 4500 TC FS1 3/220/60 220/60
GI/EMME 2000 TC FS1 3/230-400/50 230/50	GI/EMME 4500 TC FS1 3/230/50 230/50
GI/EMME 2000 TC FS1 3/400/50 230/50	GI/EMME 4500 TC FS1 3/380/60 220/60
GI/EMME 2000 TL FS1 3/220-380/60 220/60	GI/EMME 4500 TC FS1 3/400/50 230/50
GI/EMME 2000 TL FS1 3/230-400/50 230/50	GI/EMME 4500 TL FS1 3/220/60 220/60
GI/EMME 2000 TL FS1 3/400/50 230/50	GI/EMME 4500 TL FS1 3/230/50 230/50
GI/EMME 3000 TC FS1 3/220-380/60 220/60	GI/EMME 4500 TL FS1 3/380/60 220/60
GI/EMME 3000 TC FS1 3/230-400/50 230/50	GI/EMME 4500 TL FS1 3/400/50 230/50

Other versions are available on request.

▶ PRODUCT SPECIFICATION

Burner

Monoblock forced draught dual fuel burner, two stage progressive or modulating operation with a kit, made up of:

- Air suction circuit
- Fan with forward curved blades
- Air damper for setting and butterfly valve for regulating fuel output controlled by a servomotor
- Combustion head, that can be set on the basis of required output
- Maximum gas pressure switch
- Minimum air pressure switch
- Fan electrical motor
- Pump electrical motor
- Gears pump for high pressure fuel supply, fitted with:
 - filter
 - pressure regulator
 - connections for installing a pressure gauge and a a vacuumeter
 - internal by-pass for single pipe installation
- Valve unit with a double oil safety valve on the output circuit and safety valve on the return circuit
- UV photocell for flame detection
- Flame inspection window
- Slide bars for easier installation and maintenance
- Protection filter against radio interference
- IP 40 protection level.

Gas train

Fuel supply line, in the MULTIBLOC configuration (from a diameter of 3/4" until a diameter 2") or COMPOSED configuration (from a diameter of DN 65 until a diameter of DN 100), fitted with:

- Filter
- Stabiliser
- Minimum gas pressure switch
- Safety valve
- Valve seal control (for output > 1200 kW)
- One stage working valve with ignition gas output regulator.

Conforming to:

- 90/396/EEC directive (gas)
- 89/336/EEC directive (electromagnetic compatibility)
- 73/23/EEC directive (low voltage)
- EN 267 (liquid fuel burners)
- EN 676 (gas fuel burners).

Standard equipment:

- 1 flange (for GI/EMME 1400)
- 1 gas train gasket
- 8 screws for fixing the burner flange to the boiler (for GI/EMME 1400)
- 12 screws for fixing the burner flange to the boiler
- 1 insulating screen
- 2 flexible hoses for connection to the oil supply circuit
- 2 nipples for connection to the pump
- 4 wiring looms fittings for electrical connections
- 2 pin extensions
- 8 washers (for GI/EMME 1400)
- 12 washers
- Instruction handbook for installation, use and maintenance
- Spare parts catalogue.

Available accessories to be ordered separately:

- Return nozzles
- Head length reduction kit
- Sound proofing box
- RWF 40 output regulator
- Pressure probe 0-2,5 bar
- Pressure probe 0-16 bar
- Temperature probe -100-500°C
- Potentiometer kit for the servomotor
- Kit for transformation to LPG
- Gas train adapter
- Stabiliser spring
- Seal control kit.





RIELLO S.p.A. - Via degli Alpini, 1 - 37045 LEGNAGO (VR) Italy
Tel. ++39.0442630111 - Fax ++39.044221980

Internet: <http://www.rielloburners.com> - E-mail: rburners@rielloburners.com



Since the Company is constantly engaged in the production improvement, the aesthetic and dimensional features, the technical data, the equipment and the accessories can be changed.
This document contains confidential and proprietary information of RIELLO S.p.A.
Unless authorised, this information shall not be divulged, nor duplicated in whole or in part.